

NOTE: This disposition is nonprecedential.

**United States Court of Appeals
for the Federal Circuit**

ROVI GUIDES, INC.,
Appellant

v.

**KATHERINE K. VIDAL, UNDER SECRETARY OF
COMMERCE FOR INTELLECTUAL PROPERTY
AND DIRECTOR OF THE UNITED STATES
PATENT AND TRADEMARK OFFICE,**
Intervenor

2020-1994

Appeal from the United States Patent and Trademark
Office, Patent Trial and Appeal Board in No. IPR2019-
00231.

Decided: April 19, 2022

MICHAEL E. JOFFRE, Sterne Kessler Goldstein & Fox,
PLLC, Washington, DC, argued for appellant. Also repre-
sented by KRISTINA CAGGIANO KELLY, JASON DANIEL
EISENBERG, WILLIAM MILLIKEN, RYAN CHARLES
RICHARDSON.

MONICA BARNES LATEEF, Office of the Solicitor, United

States Patent and Trademark Office, Alexandria, VA, argued for intervenor. Also represented by PETER J. AYERS, KAKOLI CAPRIHAN, THOMAS W. KRAUSE, FARHEENA YASMEEN RASHEED.

Before MOORE, *Chief Judge*, TARANTO and HUGHES,
Circuit Judges.

MOORE, *Chief Judge*.

Rovi appeals from an *inter partes* review final written decision. See *Comcast Cable Commc'ns, LLC v. Rovi Guides, Inc.*, No. IPR2019-00231, 2020 WL 2305288, (P.T.A.B. May 8, 2020) (*Board Decision*). In that decision, the Patent Trial and Appeal Board held that all claims of U.S. Patent No. 9,369,741 would have been obvious over Sie¹ alone or in combination with other references. For the following reasons, we reverse.

I

Rovi owns the '741 patent, which relates to an interactive television system that supports network-based or local personal video recorder functions. Interactive television systems can, for example, allow users to record or playback broadcast television programs by pressing buttons on their remote controls. And the '741 patent purports to claim an advance in those systems. For purposes of this appeal, the parties treat claim 1 as representative:

A system comprising:

storage circuitry for storing archived copies
of videos;

control circuitry configured to:

¹ U.S. Patent Publication No. 2002/0095510 A1.

transmit a video to a plurality of user equipment, wherein the transmitting begins at a start time and ends at an end time;

access a database to determine whether an archived copy corresponding to the video is available to a user after the start time;

based on determining that the archived copy is available to the user after the start time, cause an indication corresponding to the archived copy to be displayed simultaneously with the video after a specified time after the start time but before the end time, wherein the specified time was configured prior to the start time;

receive a user response to the indication that is displayed; and

based on the received user response, retrieve, from the storage circuitry the archived copy.

(emphasis on available-to-a-user limitation).

After Rovi filed an International Trade Commission complaint against Comcast, Comcast petitioned for *inter partes* review. Comcast argued claim 1 would have been obvious over Sie alone or in combination with other references. For the available-to-a-user limitation, however, Comcast relied exclusively on the teachings in Sie. J.A. 233–35. Specifically, Comcast argued that Sie’s system determines whether a broadcast program is a club program, i.e., is stored in a database, and if so, it sends all viewers a club notification symbol. J.A. 232–35.

Rovi, in its patent owner response, challenged Comcast's reading of claim 1. It drew a distinction between a determination of "general availability"—that an archived copy is available to some users—and a determination of present "availability . . . to a *specific* user." J.A. 494 (emphasis added). Only the latter determination, in Rovi's view, meets the available-to-a-user requirement of claim 1. *See* J.A. 491. And Rovi noted the sequence of steps in the claim language: the determination of availability to the user must occur before an indication is sent to that user. *Id.*

Based on these claim construction points, Rovi argued that Sie does not teach the available-to-a-user limitation. *See* J.A. 499. It explained how Sie's club-program determination is merely a determination of general availability; a broadcast program need only be available for some users, rather than available to a specific user, to qualify as a club program. J.A. 491. Rovi acknowledged Sie does teach a determination of availability to a specific user: checking whether users are club members. But it argued that determination occurs after any notification is sent, failing to teach the sequence of steps recited in claim 1. In a footnote, Rovi explained how this holds true even in Sie's promotional and complimentary access embodiments, i.e., when Sie provides club-member benefits to non-club members. J.A. 493 n.5.

The Board agreed with Comcast, finding Sie teaches the available-to-a-user limitation. It first held that this limitation does not require prepayment; that is, the claim does not require users to pay for access to archived programs before a club notification is sent. *Board Decision* at *5. The Board, therefore, rejected Rovi's arguments about the available-to-a-user limitation, which it viewed as contingent on a prepayment requirement. *See, e.g., id.* at *15. In the alternative, it relied on Sie's promotional and complementary embodiments because those embodiments do not require payment at all. *Id.* Ultimately, the Board held

claim 1 would have been obvious over Sie. Rovi appeals. Andrew Hirshfeld, who is performing the duties of the Director of the U.S. Patent and Trademark Office, intervened in defense of the Board's decision. We have jurisdiction under 28 U.S.C. § 1295(a)(4).

II

Rovi argues that substantial evidence does not support the Board's finding that Sie teaches the available-to-a-user limitation. In part, this argument is based on Rovi's understanding of the scope of that limitation. We, therefore, start with claim construction. Then, we turn to whether a reasonable fact finder could find that Sie teaches the available-to-a-user limitation in light of our construction.

A

We review the Board's claim constructions, which do not rely on extrinsic evidence, *de novo*. See *Bradium Techs. LLC v. Iancu*, 923 F.3d 1032, 1042 (Fed. Cir. 2019). For this *inter partes* review appeal,² we give claim terms their broadest reasonable interpretation in light of the specification. See 37 C.F.R. § 42.100(b) (2018).

The available-to-a-user limitation requires the claimed system be configured to check whether an archived program is available to a *specific* user. A broader construction, which would only require the system be configured to check whether an archived program exists, would render the "to the user" language meaningless. See *Merck & Co. v. Teva Pharms. USA, Inc.*, 395 F.3d 1364, 1372 (Fed. Cir. 2005) ("A claim construction that gives meaning to all the terms of the claim is preferred over one that does not do so."). If the phrase "to the user" were stricken, claim 1 would still

² Because Comcast filed its petition before November 13, 2018, the broadest reasonable interpretation standard applies. See 37 C.F.R. § 42.100(b).

require a system configured to check whether an archived copy exists. That requirement follows from the “determine whether an archived copy corresponding to [a] video is available” limitation. So the “to a user” phrase in claim 1, presumably, must add something more. Indeed, the system must not only check whether an archived copy exists; it must ensure the specific user has access to that copy.

Also, claim 1 recites a system configured to perform an availability check *before* displaying an indication corresponding to the archived copy. That system first determines whether an archived copy is available to a user, and then, “*based on*” that determination, the system displays an indication. Thus, the availability determination must occur before the indication is displayed. Otherwise, the display step would not be “*based on*” the availability check.

B

These two points require reversal of the Board’s obviousness holding. Obviousness is a question of law with underlying fact findings, including the scope and content of the prior art. *See Bradium Techs.*, 923 F.3d at 1042. We review the Board’s factual findings for substantial evidence and the Board’s legal conclusion on obviousness *de novo*. *Id.*

No reasonable fact finder could find that Sie's club notification system³ teaches the available-to-a-user limitation. Sie's system checks for availability to a specific user only *after* the club notification is displayed. Figure 7 depicts the order of steps performed in Sie:

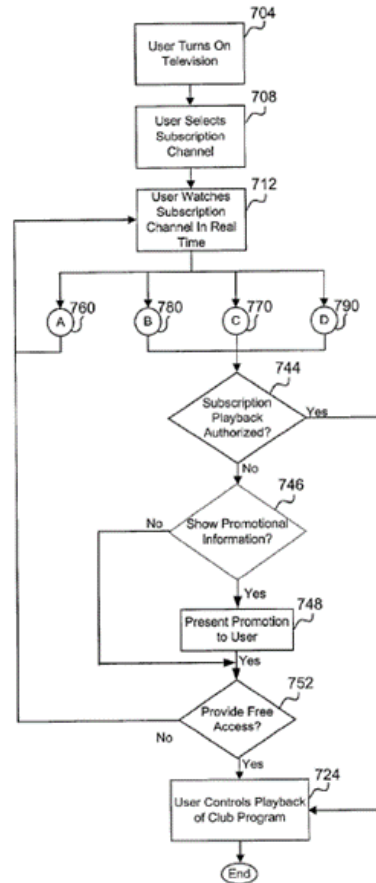

FIG. 7

³ Because Comcast's petition relied only on this system to teach the available-to-a-user limitation, J.A. 233–35, we need not consider other portions of Sie. See *SAS Inst., Inc. v. Iancu*, 138 S. Ct. 1348, 1357 (2018) (“[T]he petitioner’s contentions . . . define the scope of the litigation all the way from institution through to conclusion.”).

Step 760, illustrated as element A, represents Sie's notification service. Sie ¶ 78; *see also* Sie at Fig. 7A (detailing that service). That step occurs, if at all, before the system determines whether subscription playback is authorized for a user (step 744), whether to provide a user with promotional access (step 748), and whether to provide a user with free access (step 752). Put simply, the notification service precedes any determination of availability to a specific user. But the claim language requires the indication (i.e., the notification) to be *based on* a determination of availability to a specific user. Thus, no reasonable finder of fact could find Sie teaches the available-to-a-user limitation. And the Board erred in holding claim 1 would have been obvious based on a finding to the contrary.

III

For the foregoing reasons, we reverse. We need not, therefore, consider Rovi's arguments based on Comcast's admissions or the Administrative Procedure Act.

REVERSED

COSTS

Costs to Rovi.