

# United States Court of Appeals for the Federal Circuit

05-1128

DIGITAL CONTROL INCORPORATED and MERLIN TECHNOLOGY INC.,

Plaintiffs-Appellants,

v.

THE CHARLES MACHINE WORKS (also known as DitchWitch),

Defendant-Appellee.

J. Michael Jakes, Finnegan, Henderson, Farabow, Garrett & Dunner, L.L.P., of Washington, DC, argued for plaintiffs-appellants. Of counsel on the brief were Jeff E. Schwartz, Schwartz Sung & Webster, of Washington, DC, and Michael J. Bettinger, Preston Gates & Ellis, L.L.P., of San Francisco, California. Of counsel was Krista L. Lynch, Preston Gates Ellis & Rouvelas Meeds LLP, of Washington, DC.

Robert D. Tomlinson, Tomlinson & O'Connell, P.C., of Oklahoma City, Oklahoma, argued for defendant-appellee. With him on the brief were Mary E. Nelson, McKinney & Stringer, P.C., of Oklahoma City, Oklahoma; Gary S. Peterson; Sean V. O'Connell; and Lawrence F. Grable, Tomlinson & O'Connell, P.C., of Oklahoma City, Oklahoma.

Appealed from: United States District Court for the Western District of Washington

Judge Marsha J. Pechman

# United States Court of Appeals for the Federal Circuit

05-1128

DIGITAL CONTROL INCORPORATED and MERLIN TECHNOLOGY INC.,

Plaintiffs-Appellants,

v.

THE CHARLES MACHINE WORKS  
(also known as DitchWitch),

Defendant-Appellee.

---

DECIDED: February 8, 2006

---

Before MICHEL, Chief Judge, CLEVINGER, Senior Circuit Judge, and SCHALL, Circuit Judge.

CLEVINGER, Senior Circuit Judge.

Plaintiffs-Appellants Digital Control, Inc., and Merlin Technology, Inc. (collectively, DCI) appeal from the decision of the district court for the Western District of Washington finding that United States Patent No. 5,767,678 (the '678 patent), No. 6,008,651 (the '651 patent), and No. 6,232,780 (the '780 patent) (collectively, the patents in suit) are unenforceable for inequitable conduct.<sup>1</sup> Digital Control, Inc. v. The Charles Mach. Works, No. C03-0103P (W.D. Wash. June 9, 2004) (Bench Trial).

---

<sup>1</sup> The '678 patent, the '651 patent, and the '780 patent contain nearly identical specifications, with only the introduction and claim language differing.

The district court had previously awarded partial summary judgment to Defendant-Appellee The Charles Machine Works (CMW), finding that there was no genuine issue of material fact that misstatements and omissions made by the inventor, Dr. John Mercer, during prosecution of the patents in suit were material. Digital Control, Inc. v. The Charles Mach. Works, No. C03-0103P (W.D. Wash. Mar. 22, 2004) (Summary Judgment). After a bench trial on the issue of intent, the district court determined that the misstatements and omissions were made with intent to deceive the United States Patent and Trademark Office (PTO) and that the level of materiality and the inference of intent were both high, warranting a finding that the patents were unenforceable for inequitable conduct. Bench Trial, slip op. at 26-27.

For the reasons stated below, we find that although there are no genuine issues of material fact as to the materiality of the misstatements in Dr. Mercer's Rule 131 declaration, there are genuine issues of material fact as to the materiality of Dr. Mercer's failure to disclose prior art. As the district court's determination of inequitable conduct was premised on the materiality of both the misstatements in the Rule 131 declaration and the failure to disclose prior art, we must vacate the district court's determination that the patents were unenforceable for inequitable conduct and remand for further proceedings.

I

The patents in suit involve Horizontal Directional Drilling (HDD), which enables creation of horizontal bores in the ground through which utility lines can be laid by allowing a worker to pinpoint the location and/or orientation of a boring tool as it moves through the ground. Generally, HDD devices involve an underground transmitter

attached to a boring tool and above-ground receivers which are either stationary or, in a "walk-over system," are held by a worker walking over the tool. Conventional technology involves a display that shows the orientation or location of the tool, which is specified using values for pitch, yaw, and roll.

In 1991, Dr. Mercer filed the first in a series of 18 related patent applications regarding HDD locating technology.<sup>2</sup> In 1996, Dr. Mercer filed a continuation application that later issued as the '678 patent.<sup>3</sup> The '678 patent claims "a method of monitoring the orientation of [a] boring tool" that is "disposed within the ground", said method involving a sensor arrangement, which detects the orientation of the boring tool, and a separate transmitter that can communicate via an electromagnetic signal to an above-ground locator or receiver. That receiver, in turn, creates a visual representation of the orientation of the boring tool. '678 patent, col. 25, ll. 32-61.

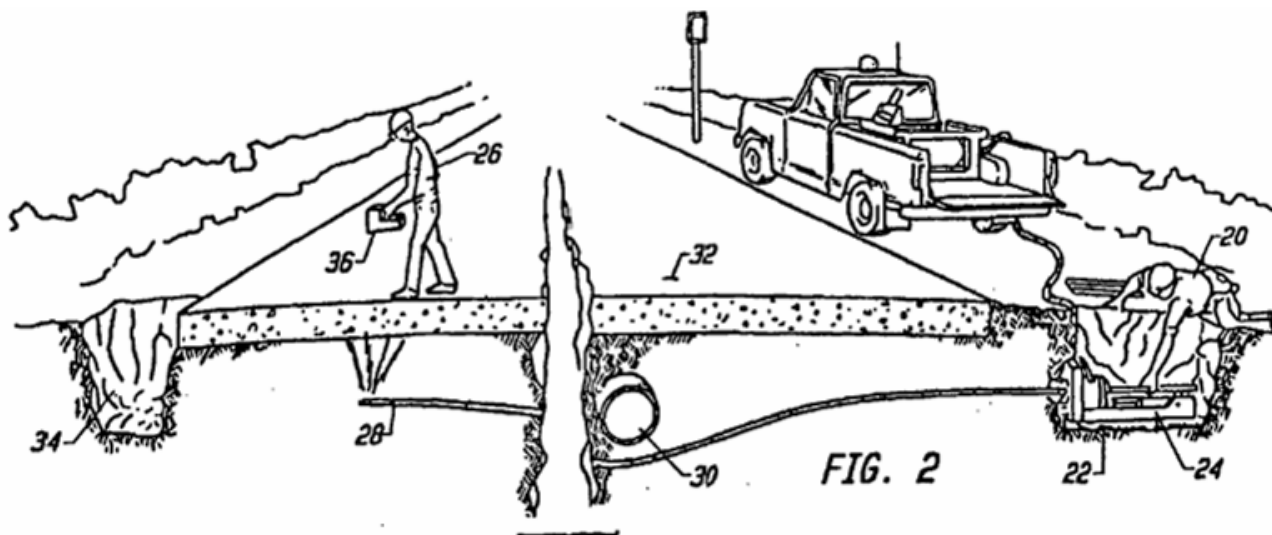

---

<sup>2</sup> DCI's complaint alleged that CMW had infringed eight of the resulting eighteen patents. However, only three of those patents, the '678 patent, the '651 patent, and the '780 patent, are the subject of the present appeal.

<sup>3</sup> The parties have agreed that a finding of inequitable conduct on the '678 patent would render all three patents unenforceable.

As illustrated in the specification at Figure 2, reproduced above, an operator (26) holding the receiver (36) uses it to locate the surface position directly above the tool head (28) and then to determine the depth and orientation (yaw, pitch, and roll) of the tool head.

Representative claim 1 of the patent reads as follows:

In a technique for locating a boring tool which is disposed within the ground, a method of monitoring the orientation of the boring tool, said method comprising the steps of:

(a) providing the boring tool with a sensor arrangement including an orientation sensor which senses at least one particular component of the orientation of the boring tool and separate transmitter means for transmitting a corresponding electromagnetic signal from the boring tool;

(b) providing an above-ground locator with a visual orientation display and with a receiver arrangement which receives said electromagnetic orientation signal and which converts it to a corresponding orientation display driving electric signal;

(c) with the boring tool in the ground at a specific orientation and the locator above ground, causing the sensor arrangement to transmit electromagnetic orientation signals corresponding to the particular orientation component of the boring tool's specific orientation;

(d) thereafter causing said receiver arrangement to produce in response to said last-mentioned electromagnetic signal a corresponding orientation display driving electric signal; and

(e) using said visual orientation display, visually displaying at the above-ground locator the particular orientation component of the boring tool's specific orientation in response to said last-mentioned orientation display driving electric signal.

'678 patent, col. 25, ll. 32-61.

Approximately half of the claims of the '678 patent were initially rejected by the PTO on the ground that they were obvious in light of U.S. Patent No. 5,174,033 (the Rider patent). In order to overcome that rejection, Dr. Mercer submitted a declaration under PTO Rule 131 (the Rule 131 declaration), whereby he submitted a sworn affidavit establishing that he had reduced his invention to practice prior to the effective date of the prior art reference, in this case, June 18, 1990. 37 C.F.R.

§ 1.131 (2004). Dr. Mercer's colleague, John Olsen, also submitted a brief declaration to the PTO stating that he had read Dr. Mercer's declaration and that he could "confirm that John Mercer showed me and operated for me in confidence the complete system referred to in that paragraph [9] at the meeting recited therein." Decl. of J. Olsen dated Oct. 2, 1997 at 1. Finding that Dr. Mercer's Rule 131 declaration was sufficient to overcome the Rider reference, the examiner withdrew the rejection.

In addition, during prosecution of the '678 patent, Dr. Mercer disclosed U.S. Patent No. 4,674,579 (the Geller patent) and U.S. Patent No. 4,806,869 (the Chau patent), both of which list Dr. Mercer as a co-inventor, as well as U.S. Patent No. 4,646,277 (the Bridges patent). '678 patent, col. 4, ll. 5-17, 38-43, col. 5, ll. 16-27. However, Dr. Mercer did not disclose U.S. Patent No. 4,710,708 (the Rorden patent), although he had submitted that patent as prior art in regard to a separate, unrelated patent application, U.S. Patent No. 6,035,951, filed on April 16, 1997.

## II

A patent may be rendered unenforceable for inequitable conduct if an applicant, with intent to mislead or deceive the examiner, fails to disclose material information or submits materially false information to the PTO during prosecution. Norian Corp. v. Stryker Corp., 363 F.3d 1321, 1330-31 (Fed. Cir. 2004). The party asserting inequitable conduct must prove a threshold level of materiality and intent by clear and convincing evidence. Molins PLC v. Textron, Inc., 48 F.3d 1172, 1178 (Fed. Cir. 1995); J.P. Stevens & Co. v. Lex Tex, Ltd., 747 F.2d 1553, 1559 (Fed. Cir. 1984). The court must then determine whether the questioned conduct amounts to inequitable conduct by balancing the levels of materiality and intent, "with a greater showing of one factor

allowing a lesser showing of the other." Union Pac. Res. Co. v. Chesapeake Energy Corp., 236 F.3d 684, 693 (Fed. Cir. 2001).

When, after a trial, the court has made factual findings as to materiality and deceptive intent, those factual findings are reviewed for clear error, and the decision of the ultimate issue of inequitable conduct is reviewed for abuse of discretion. Novo Nordisk Pharms., Inc. v. Bio-Tech. Gen. Corp., 424 F.3d 1347, 1359 (Fed. Cir. 2005).

However, when a district court grants summary judgment, we review de novo both whether there are disputed material facts and whether the prevailing party is entitled to judgment as a matter of law. SunTiger, Inc. v. Scientific Research Funding Group, 189 F.3d 1327, 1333 (Fed. Cir. 1999) (citing Conroy v. Reebok Int'l, Ltd., 14 F.3d 1570, 1575 (Fed. Cir. 1994)). In order to prevail at the summary judgment stage, the moving party must show that there are no genuine issues of material fact and that no reasonable jury could find against the moving party. Further, at the summary judgment stage, "[t]he evidence of the nonmovant is to be believed, and all justifiable inferences are to be drawn in his favor." Anderson v. Liberty Lobby, Inc., 477 U.S. 242, 255 (1986).

Determining at summary judgment that a patent is unenforceable for inequitable conduct is permissible, but uncommon. A genuine issue of material fact is not raised by the submission of "merely conclusory statements or completely insupportable, specious, or conflicting explanations or excuses." Monsanto Co. v. Bayer BioScience N.V., 363 F.3d 1235, 1240 (Fed. Cir. 2004) (quoting Paragon Podiatry Lab., Inc. v. KLM Labs., Inc., 984 F.2d 1182, 1191-92 (Fed. Cir. 1993)). Thus, we have upheld grants of summary judgment on inequitable conduct where, for example, "the affidavits submitted

to explain the representations made to the PTO were 'bare declaration[s] of lack of intent to mislead' and . . . the explanations provided in the affidavits were either 'nonresponsive' or lacked evidentiary support." Id. (quoting Paragon Podiatry, 984 F.2d at 1191-92). However, we have refused summary judgment where the plaintiff submitted an affidavit that "set[ ] forth a non-frivolous explanation that could lead a finder of fact to determine that his declaration [to the PTO] was not false or misleading," id. at 1241, or where the plaintiff "state[d] facts supporting a plausible justification or excuse for the misrepresentation," id. (quoting Paragon Podiatry, 984 F.2d at 1191).

### III

Before reviewing de novo the district court's determination that CMW was entitled to summary judgment on the issue of materiality, we must address the proper standard for determining whether a misstatement or omission is material. For many years, we have held "that materiality for purposes of an inequitable conduct determination require[s] a showing that 'a reasonable examiner would have considered such prior art important in deciding whether to allow the parent application.'" Dayco Prods., Inc. v. Total Containment, Inc., 329 F.3d 1358, 1363 (Fed. Cir. 2003) (quoting Driscoll v. Cebalo, 731 F.2d 878, 884 (Fed. Cir. 1984)). This standard is based in part on the standard of materiality articulated in the PTO's Rule 56, which describes the duty of candor and good faith, otherwise known as the duty of disclosure, before the PTO. Id.; see 37 C.F.R. § 1.56(a) (1991). However, in 1992, the PTO amended Rule 56, creating an arguably narrower standard of materiality. See Dayco, 329 F.3d at 1363-64 (noting that the PTO "amended its rules to provide a different standard for materiality"). The new Rule 56 reads as follows:



[I]nformation is material to patentability when it is not cumulative to information already of record or being made of record in the application, and

(1) It establishes, by itself or in combination with other information, a prima facie case of unpatentability of a claim; or

(2) It refutes, or is inconsistent with, a position the applicant takes in:  
(i) Opposing an argument of unpatentability relied on by the Office, or  
(ii) Asserting an argument of patentability.

A prima facie case of unpatentability is established when the information compels a conclusion that a claim is unpatentable under the preponderance of evidence, burden-of-proof standard, giving each term in the claim its broadest reasonable construction consistent with the specification, and before any consideration is given to evidence which may be submitted in an attempt to establish a contrary conclusion of patentability.

37 C.F.R. § 1.56(b) (2004).

Although we have affirmed findings of materiality based upon the new Rule 56 standard, see, e.g., Purdue Pharma L.P. v. Endo Pharms. Inc., No. 04-1189, slip op. at 8 (Fed. Cir. Feb. 1, 2006), and Bruno Indep. Living Aids, Inc. v. Acorn Mobility Servs., Ltd., 394 F.3d 1348, 1352 (Fed. Cir. 2005), we have declined to address whether the new Rule 56 standard replaced the old "reasonable examiner" standard, see Dayco, 329 F.3d at 1363-64. That is, we have not yet determined whether the new Rule 56 is the same as the "reasonable examiner" standard of the old Rule 56, or, if the new standard is narrower, whether a misstatement that is material under the "reasonable examiner" standard, but arguably not material under the new Rule 56 standard, still meets the threshold level of materiality required for a finding of inequitable conduct.

However, this is not the first time that this court has been faced with applying more than one standard of materiality. The inequitable conduct doctrine, a judicially created doctrine, was borne out of a series of Supreme Court cases in which the Court

refused to enforce patents whereby the patentees had engaged in fraud in order to procure those patents. See Precision Instrument Mfg. Co. v. Auto. Maint. Mach. Co., 324 U.S. 806 (1945); Hazel-Atlas Glass Co. v. Hartford-Empire Co., 322 U.S. 238 (1944); Keystone Driller Co. v. Gen. Excavator Co., 290 U.S. 240 (1933). Although the Supreme Court did not articulate precisely what rendered a patent unenforceable, the courts generally tended to apply a doctrine somewhat akin to that of common law fraud, albeit broader. See Digital Equip. Corp. v. Diamond, 653 F.2d 701, 709 (1st Cir. 1981); Norton v. Curtiss, 433 F.2d 779, 793 (C.C.P.A. 1970). That is, the courts required a showing that the information that was misrepresented to or withheld from the PTO was material and a showing of wrongfulness, such as deceptive intent, willful misconduct, or gross negligence. In 1949, the PTO created its first version of Rule 56, prohibiting fraud before the PTO. 37 C.F.R. §1.56 (1951).

However, neither the Supreme Court nor the PTO articulated exactly what constituted a material misrepresentation. Thus, several different standards of materiality emerged from the courts. These standards included: the objective "but for" standard, where the misrepresentation was so material that the patent should not have issued; the subjective "but for" test, where the misrepresentation actually caused the examiner to approve the patent application when he would not otherwise have done so; and the "but it may have" standard, where the misrepresentation may have influenced the patent examiner in the course of prosecution. See Am. Hoist & Derrick Co. v. Sowa & Sons, Inc., 725 F.2d 1350, 1362 (Fed. Cir. 1984) (citing Plastic Container Corp. v. Cont'l Plastics of Okla., Inc., 607 F.2d 885, 899 (10th Cir. 1979); Gemveto Jewelry Co. v. Lambert Bros., Inc., 542 F. Supp. 933, 939-40 (S.D.N.Y. 1982)).

In addition, in 1977, the PTO amended Rule 56 to clarify the duty of candor and good faith before the PTO. That version of Rule 56 required applicants to disclose "information they are aware of which is material", stating that information is material "where there is a substantial likelihood that a reasonable examiner would consider it important in deciding whether to allow the application to issue as a patent." 37 C.F.R. § 1.56 (1977). In adopting this standard of materiality, the PTO did not claim to be replacing or supplanting the existing case law addressing materiality, but rather noted that it was "codif[ying] the existing Office policy on fraud and inequitable conduct, which is believed consistent with the prevailing case law in the federal courts." Duty of Disclosure, 42 Fed. Reg. 5589 (Jan. 28, 1977).

In American Hoist, one of the first cases of inequitable conduct addressed by this court, we noted that this Rule 56 standard of materiality was yet a fourth "official standard." 725 F.2d at 1362. Although "strikingly similar to the 'but it may have' guideline," we noted that the PTO standard was "an appropriate starting point for any discussion of materiality, for it appears to be the broadest, thus encompassing the others and because that materiality boundary most closely aligns with how one ought to conduct business with the PTO." Id. at 1362-63. Further, we noted that "[t]here is no reason [ ] to be bound by any single standard," as a finding of inequitable conduct requires a balancing of materiality and intent. Id. at 1363. Thus, where "a reasonable examiner would merely have considered particular information to be important but not crucial to his decision" the requisite finding of intent must be high. Id. Conversely, where an objective "but for" standard of materiality is shown, "a lesser showing of facts from which intent can be inferred may be sufficient." Id.

Subsequent cases also discussed all four tests for materiality. See, e.g., Argus Chem. Corp. v. Fibre Glass-Evercoat Co., Inc., 759 F. 2d 10, 14 (Fed. Cir. 1985); Litton Indus. Prods., Inc. v. Solid State Sys. Corp., 755 F.2d 158, 166 n.19 (Fed. Cir. 1985); Atlas Powder Co. v. E.I. du Pont de Nemours & Co., 750 F.2d 1569, 1577-78 (Fed. Cir. 1984). However, because a party alleging inequitable conduct need only prove a "threshold level" of materiality in order to proceed to the second "balancing" portion of the inequitable conduct inquiry, and because the PTO's "reasonable examiner" standard was broader than the other three standards, the PTO standard gradually became the sole standard invoked by this court. See, e.g., A.B. Dick Co. v. Burroughs Corp., 798 F.2d 1392, 1397 (Fed. Cir. 1986) (applying the Rule 56 standard, noting that it is "[o]ne of the standards identified by this court as appropriate to determine materiality"); Akzo N.V. v. U.S. Int'l Trade Comm'n, 808 F.2d 1471, 1481 n.14 (Fed. Cir. 1986) (noting that the "major standard" for determining materiality is "identical" to the PTO's Rule 56 standard); see also Halliburton Co. v. Schlumberger Tech. Corp., 925 F.2d 1435, 1440 (Fed. Cir. 1991) (applying the "reasonable examiner" standard of materiality); Molins PLC, 48 F.3d at 1179 (same).

Even though the PTO's "reasonable examiner" standard became the dominant standard invoked by this court, in no way did it supplant or replace the case law precedent. Rather, it provided an additional test of materiality, albeit a broader and all-encompassing test. Similarly, the PTO's recent adoption of an arguably narrower standard of materiality does not supplant or replace our case law. Rather, it merely provides an additional test of materiality. That is, if a misstatement or omission is material under the new Rule 56 standard, it is material. Similarly, if a misstatement or

omission is material under the "reasonable examiner" standard or under the older three tests, it is also material. As we reasoned in American Hoist, to the extent that one standard requires a higher showing of materiality than another standard, the requisite finding of intent may be lower.

That the new Rule 56 was not intended to replace or supplant the "reasonable examiner" standard is supported by the PTO's comments during the passage of the new rule. The PTO noted that the rule "has been amended to present a clearer and more objective definition of what information the Office considers material to patentability" and further that "[t]he rules do not define fraud or inequitable conduct which have elements both of materiality and of intent." Duty of Disclosure, 57 Fed. Reg. 2021, 2024 (Jan. 17, 1992) (as quoted in Dayco, 329 F.3d at 1364).

In this case, the district court, faced with the two versions of Rule 56, determined that the new Rule 56 standard was essentially the same as the "reasonable examiner" standard, and thus applied the "reasonable examiner" standard and our case law interpreting that standard. Summary Judgment, slip op. at 9-19. Because the "reasonable examiner" standard and our case law interpreting that standard were not supplanted by the PTO's adoption of a new Rule 56, when reviewing the district court's decision, we will do the same.

#### IV

The district court determined on summary judgment that Dr. Mercer made material misrepresentations in his Rule 131 declaration and that his failure to cite the Rorden patent was a material omission. We agree with the district court that there is no genuine issue of material fact as to the materiality of the misstatements in the Rule 131

declaration. However, because what a reference teaches is a question of fact, the district court was incorrect in determining on summary judgment that the failure to cite the Rorden patent was a material omission.

As noted above, a grant of summary judgment on the issue of inequitable conduct is permissible, but uncommon. Generally, however, the concerns attendant to awards of summary judgment on inequitable conduct relate to the inherently factual nature of the issue of intent. Direct evidence of intent is rare, such that a court must often infer intent from the surrounding circumstances. Critikon, Inc. v. Becton Dickinson Vascular Access, Inc., 120 F.3d 1253, 1256 (Fed. Cir. 1997). In the summary judgment context, all inferences must be made in favor of the nonmovant; thus, it is often improper to determine at summary judgment that a patentee made intentional misstatements or omissions to the PTO. However, in this case, the court did not award summary judgment on the issue of intent, which it rightly characterized as "inherently [ ] factual." Summary Judgment, slip op. at 15. Rather, the district court determined that there were no genuine issues of material fact as to the existence of material misrepresentations and omissions.

Indeed, the factual circumstances surrounding the Dr. Mercer's Rule 131 declaration are not in dispute. The parties do not dispute the wording of the Rule 131 declaration, which describes Dr. Mercer's reduction to practice of the invention, nor the manner in which the invention was demonstrated and reduced to practice. Dr. Mercer's declaration stated that "[t]his prototype board functions to send boring tool orientation information from the boring tool, underground, to an above ground locator and actually did so prior to the Critical Date, as will be seen." Rule 131 Decl. at 3, ¶ 6. The

declaration goes on to describe a demonstration of the prototype board made to John Olsen. Id. at 3, ¶ 9. In addition, the declaration states that "[t]he system shown to John Olsen and operated for him prior to the Critical Date . . . comprised within the boring tool a sensor arrangement including pitch and roll sensors." Id. at 4, ¶ 10.

Further, the parties do not dispute that in his deposition, Dr. Mercer admitted that he did not demonstrate his invention underground and that the sensor arrangement was not "within the boring tool." Thus, Dr. Mercer's declaration that he demonstrated a system comprising a sensor arrangement "within the boring tool" was a misstatement. In addition, although DCI argues that Dr. Mercer's declaration did not state that the invention was demonstrated to John Olsen underground, there is no other plausible reading of the declaration. The declaration clearly states that the prototype board "actually" sent orientation information from a boring tool located underground to a transmitter located above ground, that this actual performance "will be seen" later in the declaration, and then describes the performance of the tool before John Olsen. Thus, the district court correctly concluded that the declaration "gives the distinct impression that Dr. Mercer demonstrated a boring tool [to John Olsen] . . . underground." Summary Judgment, slip op. at 12-13. This, too, was a misstatement.

DCI argues that these misstatements were not material, as the invention would have been reduced to practice, and therefore would be patentable, even if the system had not been tested underground, or if the sensor arrangement had not been contained within the boring tool. Thus, DCI seems to encourage us to apply a "but for" standard of materiality; since the patent would have issued, regardless of the misstatements, the misstatements cannot be material. We agree with the district court, however, that a

reasonable examiner would have considered the true nature of Dr. Mercer's reduction of the invention to practice to be important in deciding whether to allow the patent.

Under the "reasonable examiner" standard, a misstatement or omission may be material even if disclosure of that misstatement or omission would not have rendered the invention unpatentable. See, e.g., Bristol-Myers Squibb Co. v. Rhone-Poulenc Rorer, Inc., 326 F.3d 1226, 1237-38 (Fed. Cir. 2003) (withheld reference was material notwithstanding patent examiner's determination that it did not render the invention unpatentable); Hoffmann-La Roche, Inc. v. Promega Corp., 323 F.3d 1354, 1367-68 (Fed. Cir. 2003) (finding misstatements regarding an "alternative" argument in favor of patentability to be nonetheless material); PerSeptive Biosystems, Inc. v. Pharmacia Biotech, Inc., 225 F.3d 1315, 1322 (Fed. Cir. 2000) (stating that a patent may be valid and yet be rendered unenforceable due to inequitable conduct).

In addition, "affirmative misrepresentations . . . in contrast to misleading omissions, are more likely to be regarded as material." Hoffmann-La Roche, 323 F.3d at 1367 (citing Rohm & Haas Co. v. Crystal Chem. Co., 722 F.2d 1556, 1571 (Fed. Cir. 1983)). Indeed, as noted by the district court, we are especially cognizant of misstatements made in an affidavit to the PTO. As such, we have previously found that the submission of a false affidavit may be determined to be "inherently material." Refac Int'l, Ltd. v. Lotus Dev. Corp., 81 F.3d 1576, 1583 (Fed. Cir. 1996); see also Rohm & Haas, 722 F.2d at 1571 ("[T]here is no room to argue that submission of false affidavits is not material."). Thus, we have explicitly held that an affidavit, such as a petition to make special, is material as a matter of law if "it succeeds in prompting expedited consideration of the application." Gen. Electro Music Corp. v. Samick Music Corp.,



19 F.3d 1405, 1411 (Fed. Cir. 1994). Dr. Mercer made affirmative misstatements as part of an affidavit submitted with the purpose and effect of preserving his patent application. Because the patent examiner relied on Dr. Mercer's description of his reduction to practice of his invention when issuing the '678 patent, we agree with the district court that a reasonable examiner would have considered the true nature of Dr. Mercer's reduction to practice to be important, such that his misstatements unquestionably meet the threshold requirement for materiality.

As noted by the district court, inequitable conduct may also be found where a patentee has failed to disclose material information, such as a prior art reference, to the PTO. See, e.g., Baxter Int'l, Inc. v. McGaw, Inc., 149 F.3d 1321, 1327 (Fed. Cir. 1998); Molins PLC, 48 F.3d at 1178. When a defendant alleges that the patentee omitted a material reference, "there must be clear and convincing evidence that the applicant made a deliberate decision to withhold a known material reference." Baxter Int'l, 149 F.3d at 1329 (citing Molins PLC, 48 F.3d at 1181). Thus, the reference must be material, under the same standards outlined above, and the patentee must have actual knowledge of the prior art reference.

The district court found that it was undisputed that Dr. Mercer knew of the Rorden Patent during prosecution of the patents in suit, as evidenced by his submission of that reference to the PTO on April 16, 1997, during the prosecution of an unrelated patent. Summary Judgment, slip op. at 16. Further, the district court found that the Rorden patent was material, as an application for a continuation patent using the same specification, United States Patent No. 6,525,538 (the '538 patent), was rejected by the examiner as anticipated by the Rorden patent while one of the patents in suit, the '780

patent, was still pending. Thus, the district court found that "[g]iven the similarity between the '538 Patent and the '678 Patent, it is logical to assume that the '678 Patent would have been rejected on the same basis had the Rorden patent been disclosed to the examiner." Id. at 17.

However, a withheld otherwise material prior art reference is not material for the purposes of inequitable conduct if it is merely cumulative to that information considered by the examiner. Molins PLC, 48 F.3d at 1179 (citing Scripps Clinic & Research Found. v. Genentech, Inc., 927 F.2d 1565, 1582 (Fed. Cir. 1991)). The district court rejected DCI's contention that the Rorden patent was merely cumulative of those references disclosed, noting that Rorden "claims methods of determining location and orientation of the underground tool using fixed receiving stations, while Geller claims an apparatus for drilling that can be steered around obstacles." Summary Judgment, slip op. at 18. The court also found that "the Geller reference is not focused on disclosing a method of locating an underground boring tool, which is the primary subject matter in both the Rorden patent and the [ ]'678 Patent." Id. However, DCI contends that, even if the Geller reference has a different focus than that of the Rorden patent and the '678 patent, it too describes methods of determining the location and orientation of an underground boring tool using fixed receiving stations. See Geller patent, col. 4, l. 67- col. 5, l. 5 ("In operation the position of the drilling head is determined by above ground detectors which . . . determine the tool's depth and direction. The detector will also . . . be used to determine the tool's pitch.").

As this court has previously noted, the scope and content of prior art and what the prior art teaches are questions of fact. Para-Ordnance Mfg., Inc. v. SGS Importers

Int'l, Inc., 73 F.3d 1085, 1088 (Fed. Cir. 1995) (citing Stiftung v. Renishaw PLC, 945 F.2d 1173, 1182 (Fed. Cir. 1991)); In re Bell, 991 F.2d 781, 784 (Fed. Cir. 1993)). Because there are genuine issues of material fact as to what the Geller reference teaches, and thus whether the Rorden patent is cumulative of the Geller patent, the issue of whether the failure to disclose the Rorden patent was a material omission was not properly decided at summary judgment.

V

In determining whether the misstatements were intentional, "the involved conduct, viewed in light of all the evidence, including evidence of good faith, must indicate sufficient culpability to require a finding of intent to deceive." Paragon Podiatry, 984 F.2d at 1189 (quoting Kingsdown Med. Consultants Ltd. v. Hollister, Inc., 863 F.2d 867, 876 (Fed. Cir. 1988) (en banc)). Intent need not be shown by direct evidence, but may be inferred from the totality of the evidence. Molins PLC, 48 F.3d at 1180-81. Although the district court did not find direct evidence of intent to deceive, the court made numerous findings of fact regarding the circumstances surrounding Dr. Mercer's Rule 131 declaration and the omission of the Rorden patent.

The district court found that Dr. Mercer was "an extremely experienced inventor," who, at the time of his Rule 131 declaration, had applied for numerous patents and had testified as an expert witness in patent litigation. Bench Trial, slip op. at 6, 25. Thus the district court found that Dr. Mercer was aware of the duty of candor before the PTO and knew that it applied to his affidavit. The district court also found that Dr. Mercer had control over the contents of his declaration; even though the declaration was drafted by

an attorney, Dr. Mercer was provided with a draft, was asked for specific feedback, and possessed the final draft for a period of weeks prior to signing it, under oath. Id. at 6-9.

Further, the district court found that the specific misstatements in the declaration corresponded to differences between the declaration and the document on which it was based. Upon request by his attorney, Dr. Mercer acquired documentation regarding the work done on his inventions during the time in which he allegedly reduced the invention claimed in the '678 patent to practice. Dr. Mercer drafted a summary document, entitled "Development Process Leading to Filing Application #662,939." The district court found that "[i]t is obvious that this document was used as a blueprint for the [Rule 131 declaration], as many of the paragraphs in the [Rule 131 declaration] are nearly identical to those in [the summary document]." Id. at 6-7. However, the district court noted that "two crucial portions" were added, namely those portions determined to be misstatements and quoted above. Id. at 9 (noting that the declaration added the phrase, "[t]his prototype board functions to send boring tool orientation information from the boring tool, underground, to an above ground location and actually did so prior to the Critical Date, as will be seen," as well as the description of the demonstration to John Olsen).

In addition, the district court found "overwhelming evidence" that Dr. Mercer had a "motive" to mislead the PTO, as he was "under severe pressure from his largest customer . . . to acquire and enforce patent rights over products supplied by DCI." Id. at 22. The district court dismissed DCI's argument that Dr. Mercer had no motive to mislead the PTO in his declaration because he had actually reduced the invention to

practice prior to the critical date, finding that "Dr. Mercer did not know, prior to submitting his affidavit and materials to the PTO, whether his submission would be enough to convince the patent examiner that actual reduction to practice had taken place." Id.

Finally, the district court found Dr. Mercer's testimony regarding his intent to be "lacking in credibility." Id. at 11. The district court found that Dr. Mercer engaged in "constant restatement and revision . . . during the time of this litigation" stating at various times that he did not recall clearly whether he had demonstrated the prototype system within a boring tool, that he did not demonstrate the system with the sensor arrangement within the boring tool, and that he must have demonstrated "the prototype sensor arrangement to Mr. Olsen in the prototype boring tool because my declaration states that I did." Id. at 23-27. The district court also noted that Dr. Mercer attempted to blame the problem on his attorney, but found Dr. Mercer's statements "unworthy of credence" as it was only after the court had determined that the declaration was materially misleading that Dr. Mercer said "that he wasn't careful when he reviewed his Affidavit and submitted it to the PTO, and that his attorney drafted it anyway." Id. at 25.

However, the district court's finding of intent relied, in part, on the fact that it was "presented with two acts of material misstatement or omission regarding the same three patents." Id. at 21. The district court emphasized the fact that Dr. Mercer did not disclose the Rorden patent even though the '538 patent, which has the same specification as the patents in suit, had been initially rejected as anticipated by the Rorden patent. Id. at 20, 26. Further, the district court's analysis of Dr. Mercer's

credibility rested in part on the fact that he "constantly changed his reasons for why [the Rorden patent] might not have been submitted to the PTO" during the prosecution of the patents in suit. Id. at 23. In short, both the district court's determination that the failure to disclose the Rorden patent was made with intent to deceive the PTO and its determination that the misstatements in the Rule 131 declaration were made with intent to deceive the PTO were based in part on the court's improper determination at summary judgment that the failure to disclose the Rorden patent was a material omission. Further, we cannot tell how heavily the district court relied upon the materiality of the omission of the Rorden patent when assessing Dr. Mercer's credibility and when determining that the misstatements in the Rule 131 declaration were made with intent to deceive the PTO.

Finally, when determining whether to declare the patents unenforceable, the district court found that "[t]he combination of materiality and intent in the [ ] misstatements and omissions of Dr. Mercer constitute inequitable conduct. Because both materiality and inference of intent are high, a finding of inequitable conduct is warranted." Id. at 27. Like its analysis on intent, the district court's determination that the patents were unenforceable for inequitable conduct was based in part on the materiality of both the misstatements in the Rule 131 declaration and the failure to cite the Rorden patent.

Thus, despite the district court's proper grant of summary judgment on the issue of the materiality of the misstatements in the Rule 131 declaration and its ample factual findings regarding Dr. Mercer's intent to deceive with respect to the Rule 131

declaration, we cannot uphold the district court's determination that the patents in suit are unenforceable for inequitable conduct. This court has in the past found that a false affidavit, standing alone, is sufficient to render a patent unenforceable. See supra Part IV (citing Refac Int'l, 81 F.3d at 1583; Rohm & Haas, 722 F.2d at 1571; Gen. Electro Music, 19 F.3d at 1411). However, in this case, the district court did not parse its analysis of the misstatements in the Rule 131 declaration from its analysis of the failure to disclose the Rorden patent. As a result, we are unable to tell how heavily the district court's finding of inequitable conduct relied on its proper grant of summary judgment on the materiality of the misstatements in the Rule 131 declaration and how heavily it relied on its improper grant of summary judgment on the materiality of the failure to disclose the Rorden patent.

In short, we cannot ascertain whether the district court would have ruled the patents unenforceable based solely on the misrepresentations in the Rule 131 declaration, whether the district court's factual findings on intent would survive trial on the merits of the cumulative prior art issue, and in particular, whether the district court's assessment of Dr. Mercer's credibility would be different if the court were to determine after trial that the Rorden reference was in fact cumulative.

## VI

For the reasons stated above, the district court's partial grant of summary judgment on the materiality of the misstatements in the Rule 131 declaration is affirmed. The district court's partial grant of summary judgment on the materiality of the omission of the Rorden patent is reversed, and the district court's determination that the patents

were unenforceable for inequitable conduct is vacated. The case is remanded for further proceedings.

#### COSTS

No costs.

AFFIRM-IN-PART, REVERSE-IN-PART, VACATE-IN-PART AND REMAND