

United States Court of Appeals for the Federal Circuit

05-1006

FREE MOTION FITNESS, INC.
(formerly known as Ground Zero Design Corporation),

Plaintiff-Appellant,

v.

CYBEX INTERNATIONAL, INC.,

Defendant-Appellee.

FREE MOTION FITNESS, INC.
(formerly known as Ground Zero Design Corporation),

Plaintiff-Appellant,

v.

THE NAUTILUS GROUP, INC. (formerly known as Direct Focus, Inc.)
and NAUTILUS HUMAN PERFORMANCE SYSTEMS, INC.,

Defendants-Appellees.

Larry R. Laycock, Workman Nydegger, of Salt Lake City, Utah, argued for plaintiff-appellant. With him on the brief were Thomas R. Vuksinick and David R. Todd.

Casey K. McGarvey, Berman & Savage, P.C., of Salt Lake City, Utah, argued for defendant-appellee Cybex International, Inc. With him on the brief was E. Scott Savage.

Paul T. Meiklejohn, Dorsey & Whitney LLP, of Seattle, Washington, argued for defendants-appellees The Nautilus Group, Inc., et al. With him on the brief was David M. Jacobson.

Appealed from: United States District Court for the District of Utah

Senior Judge Bruce S. Jenkins

United States Court of Appeals for the Federal Circuit

05-1006

FREE MOTION FITNESS, INC.,
(formerly known as Ground Zero Design Corporation),

Plaintiff-Appellant,

v.

CYBEX INTERNATIONAL, INC.,

Defendant-Appellee.

FREE MOTION FITNESS, INC.
(formerly known as Ground Zero Design Corporation),

Plaintiff-Appellant,

v.

THE NAUTILUS GROUP, INC. (formerly known as Direct Focus, Inc.)
and NAUTILUS HUMAN PERFORMANCE SYSTEMS, INC.,

Defendants-Appellees.

DECIDED: September 16, 2005

Before RADER, DYK, and PROST, Circuit Judges.

Opinion for the court filed by Circuit Judge DYK. Dissenting opinion filed by Circuit Judge PROST.

DYK, Circuit Judge.

Free Motion Fitness, Inc. (formerly known as Ground Zero Design Corporation) (“Free Motion”) appeals from the judgment of the United States District Court for the District of Utah holding that Cybex International, Inc. (“Cybex”) and The Nautilus Group, Inc. (formerly known as Direct Focus, Inc.) and Nautilus Human Performance Systems, Inc. (collectively “Nautilus”) did not infringe the claims of United States Patent Nos. 6,238,323 B1 (the “’323 patent”) and 6,458,061 B2 (the “’061 patent”). Free Motion Fitness, Inc. v. Cybex Int’l, Inc., Nos. 01-CV-152 and 02-CV-122, slip op. at 2-3 (D. Utah Aug. 31, 2004); Free Motion Fitness, Inc. v. Cybex Int’l, Inc., Nos. 01-CV-152 and 02-CV-122, slip op. at 7 (D. Utah Aug. 10, 2004) (hereinafter Summary Judgment Order). We vacate the judgment of the district court and remand for a determination of literal infringement and infringement under the doctrine of equivalents under the correct claim construction. In this connection, we also set aside the district court’s holding that prosecution history estoppel limits the scope of equivalents.

BACKGROUND

Free Motion is the assignee of the ’323 and ’061 patents. The patents claim an exercise apparatus comprising a resistance assembly, two adjustable extension arms that pivot on an axis substantially parallel to the axis of rotation of a pulley at the end of each arm, and a cable linking the resistance assembly to the arms. Claim 1 of the ’061 patent is representative of the claims of both patents and reads:

1. An exercise apparatus, comprising:
a resistance assembly;
a cable linking a first extension arm and a second extension arm to the resistance assembly, wherein the cable includes a first strand and a second strand;
the first extension arm includes a first end pivotally supported adjacent the resistance assembly at a first pivot point rotating about a first axis and a free second end from which the first strand of the cable extends for

engagement by a user, the first end of the first extension arm further including a pulley having an axis of rotation offset from the first pivot point and rotating about an axis substantially parallel to the first axis; the second extension arm includes a first end pivotally supported adjacent the resistance assembly at a second pivot point rotating about a second axis and a free second end from which the first strand of the cable extends for engagement by a user, the first end of the second extension arm further including a pulley having an axis of rotation offset from the second pivot point and rotating about an axis substantially parallel to the second axis.

'061 patent, col. 7, l. 63–col. 8, l. 16 (emphases added).¹ The extension arms comprise both the extended portion of each arm and the locking pivot or swivel assembly at the end of each arm (what the district court called the “casting”) that permits the arms of the preferred embodiment of the invention to pivot up-and-down (like the lever on a slot machine). The preferred embodiment of the invention uses a single cable to link the resistance assembly with the arms.

Figures 6 and 7 of the '061 patent depict the preferred embodiment of the invention. Figure 6 shows the resistance assembly, the proximal ends of the arms, and the cable linking the two arms. The first and second pivot points are numbered 174, while the first and second extension arms are numbered 112 and 114. Figure 7 is a close-up of the proximal end of the first extension arm where it attaches to the resistance assembly. First extension arm 112 pivots on an axis substantially parallel to the axis of rotation of pulley 184, which is located at the first end of the first extension arm.

¹ The other independent and dependent claims of the patents contain limitations that are nearly identical and need not be discussed separately.

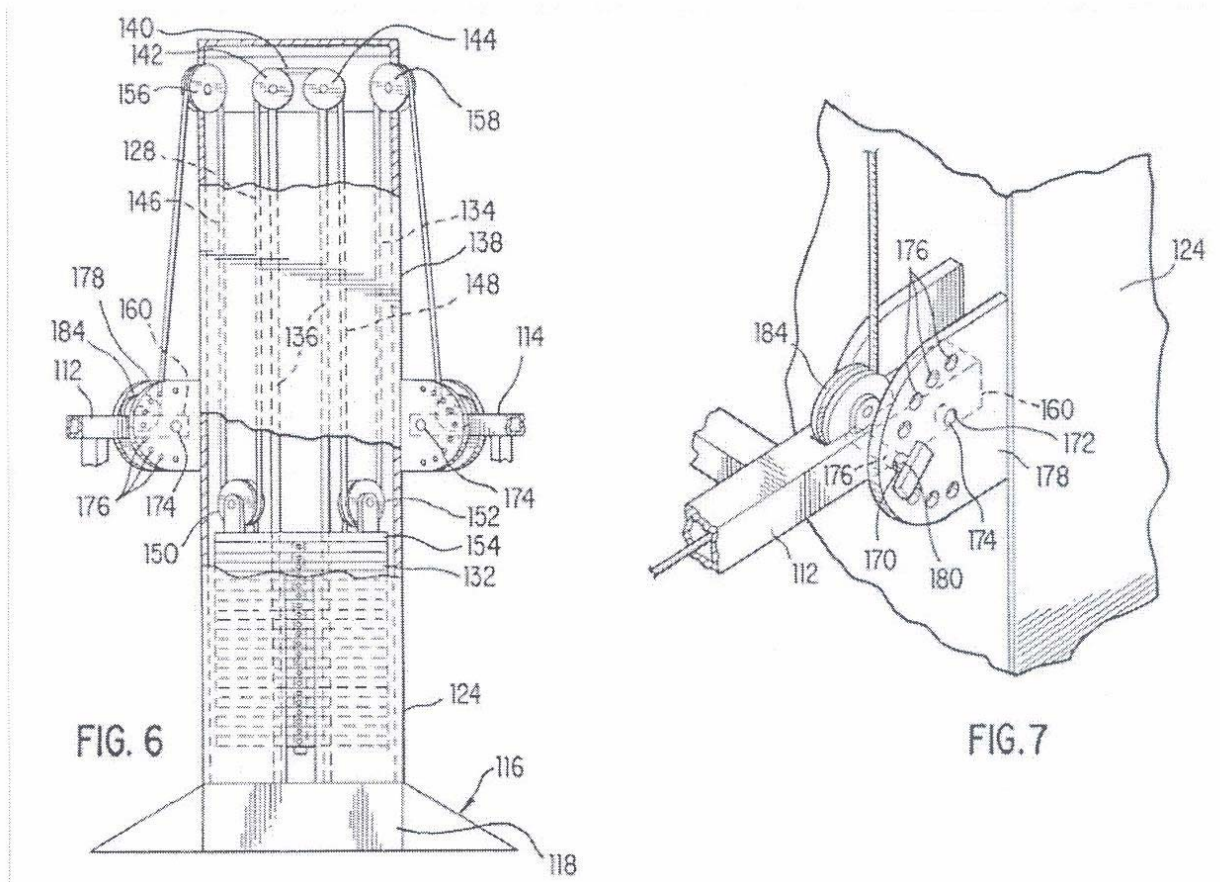

Cybox and Nautilus sell exercise machines that are alleged to be similar to those described in the patents. However, unlike the patented devices, the arms of the Cybox and Nautilus machines are attached to the resistance assembly of the machine such that they pivot in two different planes. Thus, the castings of the Cybox machine permit each arm to rotate like a doorknob at the pivot point nearest the resistance assembly and like the arms of a slot machine at the next pivot point away from the resistance assembly. The Cybox machine also uses two cables to link the resistance assembly to the arms rather than the one as in the patents' preferred embodiments. The castings of the Nautilus machine permit each arm to pivot side-to-side (like a door) at the pivot point nearest the resistance assembly and like the arms of a slot machine at the next pivot point away from the resistance assembly.

On December 3, 2001, Free Motion filed suit against Cybex for infringement of the claims of the '323 patent. On September 26, 2002, Free Motion filed suit against Nautilus for infringement of the claims of the '323 patent. Free Motion subsequently amended its complaints to add an additional claim for infringement of the claims of the '061 patent and the district court consolidated the two cases. On December 30, 2003, the district court construed various claim terms. It also granted partial summary judgment of non-infringement of claim 1 of the '061 patent based upon its claim constructions. On January 28, 2004, and February 4, 2004, Nautilus and Cybex, respectively, filed motions for complete summary judgment as to non-infringement. Those motions were granted by the district court on May 7, 2004. The district court first found the other asserted claims of the '061 and '323 patents were not literally infringed because "each of the limitations of Claim 1 of the '061 Patent are present, either expressly or by incorporation by reference, in all of [those] claims." Summary Judgment Order at 4.

The district court also ruled that a narrowing amendment made during prosecution of the '323 patent estopped Free Motion from asserting equivalence to a device having extension arms with axes of rotation transverse to the axes of rotation of the pulleys at the end of the extension arms. The court held that the estoppel applied to both patents because the '061 patent is a continuation of the '323 patent. The court subsequently dismissed with prejudice Free Motion's complaints against Cybex and Nautilus, and dismissed without prejudice Cybex's and Nautilus's counterclaims of invalidity against Free Motion. Free motion appeals. We have jurisdiction pursuant to 28 U.S.C. § 1295(a)(1).

DISCUSSION

We review both the district court's grant of summary judgment and its claim constructions without deference. Howmedica Osteonics Corp. v. Tranquil Prospects, Ltd., 401 F.3d 1367, 1370-71 (Fed. Cir. 2005). We also review the prosecution history estoppel limitation on the doctrine of equivalents without deference. Bus. Objects, S.A. v. Microstrategy, Inc., 393 F.3d 1366, 1372 (Fed. Cir. 2005).

In construing the claims we follow our recent decision in Phillips v. AWH Corp., 415 F.3d 1303 (Fed. Cir. 2005) (en banc).

The district court's grant of summary judgment of non-infringement rests on a finding that several claim limitations were not met in the accused devices. As to each of these we conclude that the district court erred.

I

The addition of unclaimed elements does not typically defeat infringement when a patent uses an open transitional phrase such as "comprising." Crystal Semiconductor Corp. v. Tritech Microelectronics Int'l, Inc., 246 F.3d 1336, 1348 (Fed. Cir. 2001) ("In the parlance of patent law, the transition 'comprising' creates a presumption that the recited elements are only a part of the device, that the claim does not exclude additional, unrecited elements."). That is essentially what the district court did here under the guise of construing the claims.

The district court found that the "first pivot point" limitation was not met by either of the accused devices. The district court held "that the first pivot point is construed as an expression of location, specifically the first pivot point is chronologically the first point that pivots on the end of the extension arm where the arm is supported by the frame"

and therefore held that “the term describes the first chronological point about which the arm turns.” Free Motion Fitness, Inc. v. Cybex Int’l, Inc., Nos. 01-CV-152 and 02-CV-122, slip op. at 13 (D. Utah Dec. 30, 2003) (emphasis in original) (hereinafter Memorandum Opinion). It appears that the district court construed “first” pivot point to mean the pivot point spatially nearest the resistance assembly. Based on this construction, the district court concluded that the asserted claims were not infringed. Summary Judgment Order at 4-5.

On appeal, the accused infringers make no effort to defend the district court’s construction of the word “first.” Cybex agrees that the word “first” in the claims identifies only the location of attachment of the first arm as opposed to the location of attachment of the second arm, and has nothing to do with the relative position of multiple pivot points on a single arm. Nautilus appears to agree.

The parties’ concession concerning the meaning of the word “first” is well taken. As we have previously held, “[t]he use of the terms ‘first’ and ‘second’ is a common patent-law convention to distinguish between repeated instances of an element or limitation.” 3M Innovative Props. Co. v. Avery Dennison Corp., 350 F.3d 1365, 1371 (Fed. Cir. 2003). In this case, the claims include two arms, and the claims’ use of the terms “first pivot point” and “second pivot point” distinguishes the pivot point on the “first extension arm” from the pivot point on the “second extension arm.” “First” does not denote spatial location, that is, it does not suggest where on the “first extension arm” or the “second extension arm” the pivot points are located. The correct construction of the word “first” merely associates the first pivot point with the first extension arm, and thus does not support the district court’s judgment that the accused devices do not infringe.

II

The district court also held that the pivot point on each arm (as described in the claims) must be “adjacent the resistance assembly.” Summary Judgment Order at 5. The district court construed the word “adjacent” to mean “that objects may or may not be in contact, but are not adjacent to each other where there is another object between them.” Memorandum Opinion at 12-13. The district court reasoned that under this definition of adjacent the claimed pivot points must be the pivot points closest to the resistance assembly. Since the claimed pivot points (those acting like a slot machine lever) were separated from the resistance assembly by another object (the other pivot point), the district court concluded that the accused devices did not infringe.

The question is whether or not the district court properly construed the term “adjacent.” There is no suggestion here that intrinsic evidence defines the term or that the term adjacent has a specialized meaning in the relevant art. Phillips, 415 F.3d at 1314. Under these circumstances, the parties and the district court looked to dictionaries for definitions of the word adjacent for assistance in determining the term’s meaning to one skilled in the art.

Our en banc decision in Phillips clarified the appropriate use of dictionaries in claim construction, rejecting the view that dictionary definitions govern unless contradicted by intrinsic evidence. Phillips, 415 F.3d at 1320. Nonetheless Phillips confirms that courts may “rely on dictionary definitions when construing claim terms” and that “[d]ictionaries . . . are often useful to assist in understanding the commonly understood meaning of words.” Id. at 1322 (quoting Vitronics Corp. v. Conceptronic, Inc., 90 F.3d 1576, 1584 n.6 (Fed. Cir. 1996)). The court must ensure that any reliance

on dictionaries accords with the intrinsic evidence: the claims themselves, the specification, and the prosecution history. Id. at 1314. Under Phillips, the rule that “a court will give a claim term the full range of its ordinary meaning,” Rexnord Corp. v. Laitram Corp., 274 F.3d 1336, 1342 (Fed. Cir. 2001), does not mean that the term will presumptively receive its broadest dictionary definition or the aggregate of multiple dictionary definitions, Phillips, 415 F.3d at 1320-1322. Rather, in those circumstances where reference to dictionaries is appropriate, the task is to scrutinize the intrinsic evidence in order to determine the most appropriate definition. Id. at 1322-23, 1324.²

Webster’s Third New International Dictionary provides several different definitions of “adjacent,” two of which are possibilities here. One definition is “not distant” and the other is “relatively near and having nothing of the same kind intervening.”³ The specification here is most consistent with defining adjacent to mean “not distant.” We find nothing in the intrinsic record suggesting a concern with intervening pivot points or excluding an additional pivot point between the “first pivot point” and the resistance assembly, particularly given that a “pivot point” and a “resistance assembly” are not

² “[A] judge who encounters a claim term while reading a patent might consult a general purpose or specialized dictionary to begin to understand the meaning of the term, before reviewing the remainder of the patent to determine how the patentee has used the term.” Phillips, 415 F.3d at 1324.

³ The full definition defines adjacent as

1a : not distant or far off . . . : nearby but not touching . . . b : relatively near and having nothing of the same kind intervening : having a common border: ABUTTING, TOUCHING : living nearby or sitting or standing relatively near or close together . . . c : immediately preceding or following with nothing of the same kind intervening.

Webster’s Third New International Dictionary of the English Language Unabridged 26 (2002).

items of the “same kind”. Renishaw PLC v. Marposs Societa’ Per Azioni, 158 F.3d 1243, 1250 (Fed. Cir. 1998) (“[W]here there are several common meanings for a claim term, the patent disclosure serves to point away from the improper meanings and toward the proper meaning.”). The specification thus suggests that “adjacent” simply means “not distant.”⁴ Indeed, Nautilus and Cybex appeared to agree before the district court that adjacent means “near.” (J.A. at 682, 2392, 2395.) Under this definition the district court’s judgment of non-infringement is not supported because the pivot points of the accused devices are not distant from the resistance assembly.

III

Nautilus, relying on other language in the claims, argues that the claimed pivot point must be the pivot point closest to the resistance assembly. Nautilus specifically argues that the claim terms “support” and “end” require that construction because a pivot point not closest to the resistance assembly cannot support the entire arm and cannot be located at the end of the arm. Cybex appears to support this argument as well. The district court apparently did not rely on this argument in granting summary judgment of non-infringement. We discern nothing in the use of the word “support” suggesting that the arm must be entirely supported by the claimed pivot point. We also disagree that the term “end” requires that the claimed pivot point be nearest the

⁴ Nautilus argues that we should construe “adjacent” with an eye toward preserving the validity of the claims. It urges that construing adjacent to mean “near” would render the claim indefinite because the accused device is not large and a pivot point at the far end of the arm is still near. We reject Nautilus’s argument because a court may only construe claims to preserve their validity when “‘after applying all the available tools of claim construction . . . the claim is still ambiguous.’” Phillips, 415 F.3d at 1327 (citing Liebel-Flarsheim Co. v. Medrad, Inc., 358 F.3d 898, 911 (Fed. Cir. 2004)). The claim in this case is not ambiguous.

resistance assembly. The district court construed “end” to mean “the portion having length, not limited to the terminus.” Memorandum Opinion at 12. No party challenges this construction. These terms require nothing more than that the pivot point be located at the end portion of the arm and contribute to supporting the arm.⁵

IV

Finally, the district court held that the term “a cable linking” in the claims is limited to only a single cable. Id. at 7-8. This issue is not pertinent to alleged infringement by the Nautilus machine. But under this construction the district court held that the Cybex device does not infringe because it “has multiple cables rather than a single cable which links that [sic] arms to the resistance assembly.” Id. at 14. The district court reached this construction by pointing to the patents’ numerous references to a single cable (“a cable linking” and “the cable”) and inferring from the patents’ use of the plural in other instances “that if the patent intended more than one cable, it would have expressly indicated that by using a plural term.” Id. at 7-8.⁶

⁵ Cybex also relies on “the” as supporting a claim construction limited to only one pivot point on each arm. As discussed below, the articles “a” and “the” do not suggest singularity. Nothing in the patent overcomes the presumption that these terms mean one or more.

⁶ The district court also found that various corrections made to the ‘061 patent evinced an intent to claim an apparatus having only a single cable. The district court wrote:

The Court observes that on October 1, 2002, a certificate of correction was filed with the United States Patent and Trademark Office (“USPTO”) regarding the ‘061 patent. The Correction substituted certain words for other words in the patent. Among the twelve corrections made: ‘apparatuses’ was changed to ‘apparatus;’ and ‘arm’ was changed to ‘arms.’ These two corrections changed the pluralized term to the singular term and vice versa respectively. It can be inferred, therefore, that if the

At oral argument Cybex admitted that the legal meaning of the term “a” suggests that the claim term “a linking cable” normally should be interpreted to mean one or more cables. That is correct. “[A]’ or ‘an’ in patent parlance carries the meaning of ‘one or more’ in open-ended claims containing the transitional phrase ‘comprising.’” KCJ Corp. v. Kinetic Concepts, Inc., 223 F.3d 1351, 1356 (Fed. Cir. 2000). This convention is overcome only when “the claim is specific as to the number of elements” or “when the patentee evinces a clear intent to . . . limit the article.” Id. Cybex argues that here the presumption is overcome because the specification describes the cable as a “single cable.” We disagree. The references to a single cable in the specification are found in the description of the preferred embodiments, and do not evince a clear intent by the patentee to limit the article to the singular. RF Del., Inc. v. Pac. Keystone Techs., Inc., 326 F.3d 1255, 1263 (Fed. Cir. 2003) (“[W]hen a claim term is expressed in general descriptive words, it typically will not be limited to a numerical range that may appear in the written description as referring to a preferred embodiment or in other, narrower claims.”); Renishaw, 158 F.3d at 1248 (reciting the familiar maxim that “one may not read a limitation into a claim from the written description”).

We also reject Cybex’s argument that use of the word “the” in connection with the word “cable” later in the claim shows that the earlier reference to “a” denotes singularity. Like the words “a” and “an,” the word “the” is afforded the same presumptive meaning of “one or more” when used with the transitional phrase “comprising.” See AbTox, Inc. v.

patent intended more than one cable, it would have expressly indicated that by using a plural term.

Memorandum Opinion at 7-8. That inference is not warranted.

Exitron Corp., 122 F.3d 1019, 1023 (Fed. Cir. 1997) (“[P]atent claim parlance also recognizes that an article can carry the meaning of ‘one or more,’ for example in a claim using the transitional phrase ‘comprising.’”).

The construction that claim 1 is not limited to a single cable is also supported by the doctrine of claim differentiation. Both patents contain dependent claims limited to devices having only one cable. Claim 2 of the ’323 patent claims “[t]he exercise apparatus according to claim 1, wherein the cable consists essentially of a single cable.” ’323 patent, col. 8, ll. 26-27. So too claim 7 of the ’061 patent requires a “single cable.” ’061 patent, col. 8, ll. 39-53. The doctrine of claim differentiation “create[s] a presumption that each claim in a patent has a different scope.” Comark Communications, Inc. v. Harris Corp., 156 F.3d 1182, 1187 (Fed. Cir. 1998). The difference in meaning and scope between claims is presumed to be significant “[t]o the extent that the absence of such difference in meaning and scope would make a claim superfluous.” Tandon Corp. v. United States Int’l Trade Comm’n, 831 F.2d 1017, 1023 (Fed. Cir. 1987). Here, dependent claims limiting the claim to a single cable confirm that the independent claims may encompass more than one cable.

Cybex relies on Insituform Technologies, Inc. v. Cat Contracting, Inc., 99 F.3d 1098 (Fed. Cir. 1996) for the opposite proposition. Insituform Techs., Inc. v. Cat Contracting, Inc., 99 F.3d 1098 (Fed. Cir. 1996). Insituform involved a method of impregnating an absorbent layer of material in a tube with resin by applying a vacuum through the wall of the tube using a cup. Id. at 1104. The claimed method specifically described moving the cup to a location farther down the tube as the resin moved through the tube. Id. We construed “a cup” and “the cup” as singular because the

claims, specification, and file history all supported that construction. Id. at 1105-06. That is not the situation before us in this case, where the claims and specification point in the opposite direction.

Therefore, we hold that “a cable linking” means “one or more cables linking.” Under the correct claim construction the fact that the Cybex device has more than one cable does not show non-infringement.⁷

V

Given changes in the claim construction, we need not address the overall availability of the doctrine of equivalents. We do address, however, one aspect of the district court’s doctrine of equivalents analysis because the district court seemed to find a disclaimer of claim scope that could be equally applicable to literal and equivalent infringement. Pall Corp. v. PTI Techs. Inc., 259 F.3d 1383, 1392 (Fed. Cir. 2001), vacated on other grounds, PTI Techs., Inc. v. Pall Corp. Techs., Inc., 535 U.S. 1109 (2002) (“Even where the ordinary meaning of the claim is clear, it is well-established that ‘the prosecution history limits the interpretation of claim terms so as to exclude any interpretation that was disclaimed during prosecution.’”) (quoting Southwall Techs., Inc. v. Cardinal IG Co., 54 F.3d 1570, 1576 (Fed. Cir. 1995)). The district court held that Free Motion was estopped from claiming infringement under the doctrine of equivalents because, during prosecution of the ’323 patent, the district court found that Free Motion disclaimed a device wherein the axes of rotation of the guide pulleys and extension

⁷ Cybex also appears to argue that its machine does not infringe because neither cable of the Cybex machine links the extension arms to the resistance assembly. This argument relies on an overly restrictive construction of “linking” and is rejected.

arms were perpendicular. Summary Judgment Order at 6. The district court held that the disclaimer applied to both patents because the '061 patent is a continuation of the '323 patent. Id. at 6 n.3. During prosecution the examiner rejected the pending claims, as he found that they were anticipated by Fitzpatrick. The Fitzpatrick patent discloses an exercise device wherein the axes of rotation of the adjustable arms are transverse to the axes of rotation of the pulleys. U.S. Patent No. 4,826,157 (issued May 2, 1989). This orientation can be best understood by reference to Figure 3 of Fitzpatrick. Arms 35 are mounted in sleeves 34 such that they rotate on an axis of rotation transverse to guide pulleys 37.

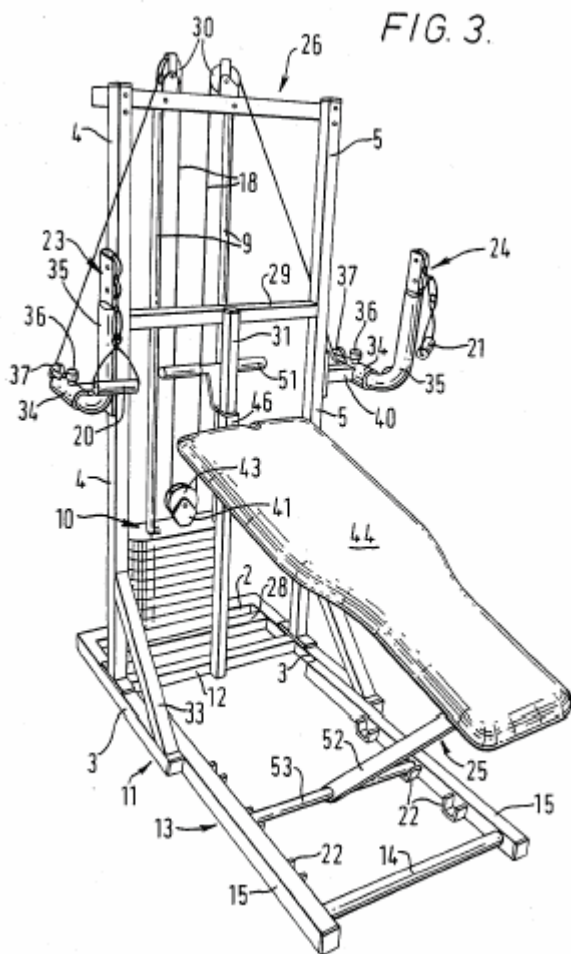

Free Motion overcame the rejection to the prior art Fitzpatrick patent by amending the claims to include a “rotating about an axis substantially parallel to the second axis” limitation and made the following argument in connection with the amendment:

The undesirable forces created by the transverse orientation of the pulley 38 disclosed by Fitzpatrick is [sic] in direct contrast with the claimed invention where the axes of the respective pulleys are is [sic] substantially parallel to the axes of rotation of the extension arms. The claimed assembly provides for virtually no variation in cable tension when the extension arms are selectively rotated.

(J.A. at 3109.) The district court concluded that Free Motion was estopped to assert infringement by a device that—although including extension arms with axes of rotation substantially parallel to the pulleys—also has the undesirable features of Fitzpatrick. Basic patent law holds that a party may not avoid infringement of a patent claim using an open transitional phrase, such as comprising, by adding additional elements. Crystal Semiconductor, 246 F.3d at 1348. The presence of an undesirable prior art feature in addition to the elements recited in the claim, even when the undesirability of that feature formed the basis of an amendment and argument overcoming a rejection during prosecution, does not limit the claim unless there is a clear and unmistakable disclaimer of claim scope. Here, there is no such disclaimer. The “comprising” language allows additional features. The disclaimer, if there was one, only applied to the “claimed assembly,” not unclaimed features added to the patented device.

CONCLUSION

We vacate the district court’s grant of summary judgment of non-infringement and remand for a determination of literal infringement and infringement under the doctrine of equivalents under the correct claim construction. In this connection, we

disapprove the district court's holding that prosecution history estoppel limits the scope of equivalents. Cybex and Nautilus are free, of course, to reinstate their counterclaims upon remand.⁸

COSTS

No costs.

VACATED AND REMANDED

⁸ Cybex invites us to hold the patents invalid as obvious. This issue is not ripe for decision and is not properly before this court because a cross-appeal was not filed. Typeright Keyboard Corp. v. Microsoft Corp., 374 F.3d 1151, 1157 n.4 (Fed. Cir. 2004) (“[W]here the appellee urges invalidity as a new ground on which to support a judgment of non-infringement . . . a cross-appeal is necessary since a judgment of invalidity is broader than a judgment of non-infringement.”).

United States Court of Appeals for the Federal Circuit

05-1006

FREE MOTION FITNESS, INC.
(formerly known as Ground Zero Design Corporation),

Plaintiff-Appellant,

v.

CYBEX INTERNATIONAL, INC.,

Defendant-Appellee.

FREE MOTION FITNESS, INC.
(formerly known as Ground Zero Design Corporation),

Plaintiff-Appellant,

v.

THE NAUTILUS GROUP, INC. (formerly known as Direct Focus, Inc.)
and NAUTILUS HUMAN PERFORMANCE SYSTEMS, INC.,

Defendants-Appellees.

PROST, Circuit Judge, dissenting.

I respectfully disagree with several aspects of the majority's claim construction in this case. I would affirm the decision of the district court, because I agree with its constructions of "first pivot point" (as I understand that construction), "adjacent," and "a cable linking."

With respect to the "first pivot point," I believe the majority has been misled by Free Motion's characterization of the district court's claim construction. Although the

district court's opinion is admittedly somewhat unclear on this point, I do not share the majority's belief that the district court relied on the word "first" to denote spatial location, rather than to distinguish the pivot point on the "first extension arm" from the one on the "second extension arm." Such a holding would obviously have been incorrect. I fully agree with the majority that "first" and "second" are used in claim 1 according to the "common patent-law convention to distinguish between repeated instances of an element or limitation," 3M Innovative Properties Co. v. Avery Dennison Corp., 350 F.3d 1365, 1371 (Fed. Cir. 2003), but I think the district court understood this, too.¹ Free Motion has portrayed the district court's holding in a different way in order to set up an easy target to attack on appeal. As Cybex argues, identifying the "first pivot point" as "the first in location among a series of pivot points" "was not the district court's ruling, and [Free Motion]'s argument against it is meaningless."

An alternative reading of the district court's construction is consistent with the conventional use of "first" and "second." Specifically, I understand the court to have concluded, based on the context of the claim and the written description, that the position of the first and second pivot points was limited. The court's coincidental use of the word "first" to describe that particular position ("first chronological point about which the arm turns") understandably caused some confusion over whether the court correctly interpreted the word "first" in the claim. But I read the district court's holding as not based on the word "first"; its interpretation applies equally to the "second pivot point," such that it would have been entirely consistent (and somewhat redundant) for the court

¹ Like the majority, I confine my discussion to claim 1 of the '061 patent. See ante at 3, n.1. Free Motion does not present any additional arguments in its appeal regarding the other asserted claims.

to have inserted “and the second pivot point is chronologically the first point that pivots on the end of the second extension arm where the arm is supported by the frame.”

Several pieces of intrinsic evidence support this construction. The specification places the “first pivot point” where the first end of the first extension arm is “pivotally supported adjacent the resistance assembly.” Where there are multiple pivot points, only the pivot point nearest the resistance assembly can pivotally support the entire arm. Moreover, as discussed in more detail below, “adjacent” should be construed as “relatively near and having nothing of the same kind intervening.” With that construction in mind, the context of the claim makes it indisputably clear that the first and second pivot points are, as the district court held, “on the end of the extension arm where the arm is supported by the frame.” Even if the majority’s interpretation of the district court’s claim construction is correct, I would still affirm the judgment of noninfringement based on my belief that the claim context and written description restrict the “first pivot point” and “second pivot point” to particular locations.

I also think the district court properly selected the appropriate dictionary definition of “adjacent.”² As the majority states, a claim term does not “presumptively receive its broadest dictionary definition or the aggregate of multiple dictionary definitions[.]” Ante at 9. When I “scrutinize the intrinsic evidence in order to determine the most appropriate definition[.]” id., I find nothing that supports a meaning as broad as “not distant.” I only find support for “relatively near and having nothing of the same kind intervening.” Nothing in the specification describes a pivot point that has another pivot

² In this case, the parties only advocate constructions of “adjacent” based on dictionary definitions.

point between it and the resistance assembly as “adjacent” to the assembly. Such a disclosure would be necessary to convince me that the broader definition should apply.

Moreover, the narrower definition appears more consistent with ordinary English usage. For example, Connecticut is near New Jersey, but one does not describe them as “adjacent.” A part of another state, New York, lies in between. One also normally refers to contiguous squares on a checkerboard as “adjacent” to each other, but the space two squares away is not considered “adjacent,” even though it is relatively “near.”

The majority’s reasoning appears to start with the broadest definition and consult the written description only to see if that definition is narrowed, rather than determining whether the specification discloses anything broader than the narrow definition. Phillips v. AWH Corp. explains:

The problem is that if the district court starts with the broad dictionary definition in every case and fails to fully appreciate how the specification implicitly limits that definition, the error will systematically cause the construction of the claim to be unduly expansive. The risk of systematic overbreadth is greatly reduced if the court instead focuses at the outset on how the patentee used the claim term in the claims, specification, and prosecution history, rather than starting with a broad definition and whittling it down.

415 F.3d 1303, 1321 (Fed. Cir. 2005) (en banc). The majority’s approach, in my view, does not attempt to determine what the inventor actually invented, but rather takes the broadest available abstract meaning of a claim term that is not explicitly rejected by the specification. This approach allows the claim scope to extend beyond what the inventor’s written description and claims show to be his actual invention. Free Motion’s inventor came up with a specific structure that he described and claimed. By deviating from the meaning of “adjacent” that is most closely aligned with all the examples in the specification, the majority awards him more than he actually invented and claimed.

As the accused products lack a “first pivot point” and “second pivot point” that are “adjacent the resistance assembly,” I would affirm the district court’s judgment of noninfringement. Such a decision would not require interpreting the “cable” term.

For the record, though, I do not share the majority’s desire to overrule the district court’s interpretation of that term. The majority relies on Cybex’s admission that “a” or “an” typically means “one or more” in an open-ended “comprising” claim. Ante at 12. However, it should be noted that Cybex’s counsel was only acknowledging our precedent on the use of indefinite articles. He did not go so far as to “suggest[] that the claim term ‘a linking cable’ normally should be interpreted to mean one or more cables.” Id. Counsel made no concession about the claim language at issue here, which includes the word “linking”; the ’061 patent claims “a cable linking” the arms and the resistance assembly. A cable that is only one of several would not “link” these things because other cables would also form part of the connection. “A cable linking” means that the cable is linking the specific things that follow in the claim text. That is, it must be attached to each of those things.

Additionally, the majority is simply wrong to state that the written description supports a multi-cable construction. There are no references to any structure with multiple “cables linking” the arms to the resistance assembly. In fact, the written description states that both disclosed embodiments of the invention employ “a single cable.” ’061 patent, col. 3, ll. 11-13, 39-41 (“functional lift exercise” embodiment); col. 5, ll. 47-48 (“cable crossover exercise” embodiment) (emphasis added). The patent does not suggest that multiple cables could “link” the arms to the resistance assembly. The disclosure of “a single cable” in each embodiment and the requirement of this cable

“linking” the arms to the resistance assembly distinguishes this case from the precedent cited by the majority, in which “a” or “the” was presumed to mean “one or more” when used in a “comprising” claim. See KCJ Corp. v. Kinetic Concepts, Inc., 223 F.3d 1351, 1355-57 (Fed. Cir. 2000); AbTox, Inc. v. Exitron Corp., 122 F.3d 1019, 1023-24 (Fed. Cir. 1997). This case is more like Insituform Technologies, Inc. v. Cat Contracting, Inc., in which this court construed “a cup” and “the cup” as singular when a plural construction was inconsistent with the claim context and “neither the specification nor the drawings disclose[d] more than one cup.” 99 F.3d 1098, 1105-06 (Fed. Cir. 1996); see also N. Am. Vaccine, Inc. v. Am. Cyanamid, 7 F.3d 1571, 1575-76 (Fed. Cir. 1993) (construing “a . . . linkage to a terminal portion of the polysaccharide without significant crosslinking” as singular because “there is no indication in the patent specification that the inventors here intended [the article ‘a’] to have other than its normal singular meaning” and “[a]ll references to polysaccharide linkages speak of a linkage, not multiple linkages”).

I would also affirm the district court’s application of prosecution history estoppel on the basis provided by that court. The court specifically held that “Free Motion is estopped from asserting that [the] perpendicular orientation [of the axes of rotation in the accused devices] is equivalent to the ‘substantially parallel’ element of the patents-in-suit.” I agree with that determination, as far as it goes. Under my view of the “pivot point” and “adjacent” issues, it goes far enough to affirm the judgment of noninfringement, and therefore I express no opinion on the majority’s disclaimer-of-scope analysis.

For these reasons, I respectfully dissent.