

NOTE: This disposition is nonprecedential.

**United States Court of Appeals
for the Federal Circuit**

JOHN R. WILSON,
Appellant

v.

**GREGORY ROGER MARTIN, ALLISON JEAN
TANNER,**
Appellees

2018-1980

Appeal from the United States Patent and Trademark
Office, Patent Trial and Appeal Board in No. 106,060.

Decided: October 21, 2019

DEVAN V. PADMANABHAN, Padmanabhan & Dawson,
PLLC, Minneapolis, MN, argued for appellant. Also repre-
sented by ERIN DUNGAN, PAUL J. ROBBENOLT, SRI
SANKARAN.

LINDA T. COBERLY, Winston & Strawn LLP, Chicago,
IL, argued for appellees. Also represented by KIMBALL
RICHARD ANDERSON; MICHAEL L. GOLDMAN, ANDREW PETER
ZAPPIA, Pepper Hamilton LLP, Rochester, NY.

Before PROST, *Chief Judge*, REYNA and STOLL, *Circuit Judges*.

REYNA, *Circuit Judge*.

John R. Wilson appeals from a decision of the Patent Trial and Appeal Board in an interference proceeding finding certain claims of U.S Patent No. 8,809,044 unpatentable as anticipated or obvious. Because substantial evidence supports the Board's finding that the prior art discloses the claimed "ambient gas" limitation, and the Board did not abuse its discretion by refusing to apply judicial estoppel, we *affirm*.

BACKGROUND

I. The '044 Patent and the '267 Application

John R. Wilson is the listed inventor on U.S. Patent No. 8,809,044 ("the '044 patent"), which is entitled "Highly Efficient Gas Permeable Devices and Methods for Culturing Cells." The '044 patent, assigned to Wilson Wolf Manufacturing Corporation, is directed to methods of using gas-permeable devices to culture animal cells. '044 patent, Abstract; J.A. 8. The '044 patent teaches that cells are generally cultured in the presence of oxygenated gas and a liquid culture medium that provides the cells with nutrients. *See id.* col. 3 ll. 37–47. The '044 patent describes a cell culture device having multiple vertical shelves containing two or more culture compartments into which cells and a culture medium are placed. *Id.* col. 4 ll. 36–38, col. 8 ll. 41–48, col. 12 ll. 47–54. The culture compartments are connected by a manifold and include an access port through which cells and medium are added or removed. *Id.* col. 9 ll. 20–22. These compartments include at least one wall that is comprised of a gas-permeable material and are separated by a space which contains oxygenated gas. *Id.* col. 8 ll. 42–45. This gas passes through the gas-permeable portions of the culture compartment and delivers oxygen to the

cells. *Id.* col. 10 ll. 17–21. The '044 patent discloses that this oxygenated gas is preferably “ambient gas.” *Id.* col. 9 ll. 35–37.

Figure 3 of the '044 patent illustrates an embodiment of this cell culture device, where oxygenated gas 100 flows from gas space 50 to cells 90 placed within culture compartments 20:

FIG. 3

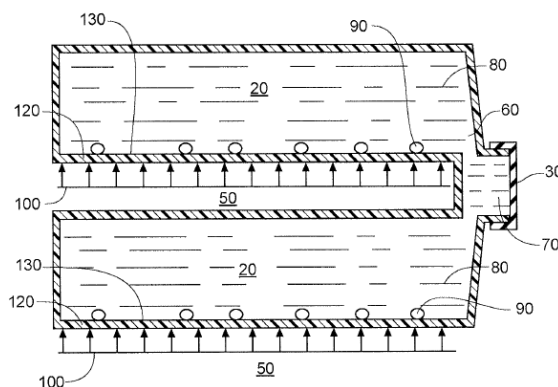

Id. Fig. 3, col. 10 ll. 17–21.

Gregory Roger Martin and Allison Jean Tanner (collectively, “Martin”) are the listed inventors on U.S. Patent Application No. 14/814,267, entitled “Multilayered Cell Culture Apparatus” and published as U.S. Patent Application Publication No. 2015/0337252 on November 26, 2015 (“the '267 application”). The '267 application was filed by Corning Incorporated (“Corning”). Like the '044 patent, the '267 application is also directed to a cell culture device with two or more culture compartments comprised of a gas-permeable material that permits the delivery of oxygenated gas to the cells being cultured within. '267 application, ¶ 11.

Every claim at issue in this appeal requires that the cells are cultured in the presence of “ambient gas.” Independent claim 1 of the '044 patent corresponds to the interference count and recites:

1. A method of culturing animal cells in a gas permeable multi-shelf cell culture apparatus, the method comprising:

adding animal cells and media into a gas permeable multi-shelf apparatus comprising two or more culture compartments, each compartment including a shelf comprised of gas permeable, liquid impermeable material for cells to reside upon, each shelf connected to an opposing surface, a fluid pathway shared by said culture compartments, and each said shelf is in contact with a gas space,

whereby said apparatus is incubated *in the presence of ambient gas* suitable for animal cell culture, oriented in a position such that said culture compartments are located one above the other, each said shelf is in a horizontal position with said gas space located below it, animal cells reside upon at least a portion of each said shelf, said culture compartments include media in contact with said shelf and said opposing surface, and ambient gas resides within each said gas space and is in contact with each shelf.

'044 patent col. 30 ll. 18–37 (emphasis added).

Independent claim 2 of the '267 application, which is almost identical to claim 1 of the '044 patent, corresponds to the interference count and recites:

2. A method of culturing cells in a gas permeable multi-shelf cell culture apparatus, the method comprising:

adding cells and media into a gas permeable multi-shelf apparatus comprising two or more culture compartments, each

compartment including a shelf comprised of gas permeable, liquid impermeable material for cells to reside upon, each shelf connected to an opposing surface, a fluid pathway shared by said culture compartments, and each said shelf is in contact with a gas space,

whereby said apparatus is incubated *in the presence of ambient gas* suitable for cell culture, oriented in a position such that said culture compartments are located one above the other, each said shelf is in a horizontal position with said gas space located below it, cells reside upon at least a portion of each said shelf, said culture compartments include media in contact with said shelf and said opposing surface, and ambient gas resides within each said gas space and is in contact with each shelf.

'267 application at 7.

II. Toner

U.S. Patent No. 6,759,245 (“Toner”), entitled “Cell Culture Systems and Methods for Organ Assist Devices,” is directed to systems and methods for culturing animal cells using modular cell culturing devices with gas-permeable membranes. J.A. 1540 (Toner col. 1 ll. 20–21, col. 2 ll. 35–36, 51–53). Toner teaches that by using a gas-permeable, liquid-impermeable membrane for the culture compartment, the delivery of oxygen to the cells may be separated from delivery of the culture medium. J.A. 1540, 1542 (Toner col. 2 ll. 36–43, col. 5 ll. 52–53). To deliver oxygen to the cells, Toner discloses using an “oxygenated fluid,” and explains that “[o]xygenated fluids can be gases or liquids, and can include air . . . and other gasses commonly found in nature.” J.A. 1543 (Toner col. 7 ll. 63–65, col. 8 ll. 3–9). Toner further discloses that the oxygenated fluid

can be supplied to the interior of the culture compartment “through an opening,” such as “a port or manifold.” *Id.* (Toner col. 8 ll. 43–51). “Other ports” may be also added “for air displacement” or “for venting oxygenated fluids.” J.A. 1549 (Toner col. 19 ll. 43–46, 50–53). The flow of oxygenated fluid through the interior of the cell culture device “can be static, in any one direction, or in multiple directions.” J.A. 1548 (Toner col. 17 ll. 1–2).

Toner’s Figures 8a and 8b are relevant to this appeal. Figure 8a illustrates a preferred embodiment of Toner’s cell culture device with three culture compartments:

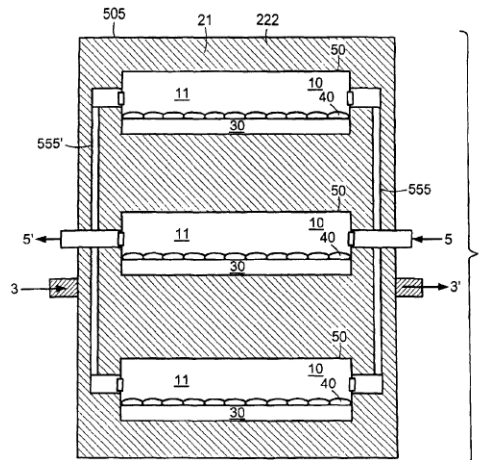

FIG. 8a

J.A. 1526 (Toner Fig. 8a). Each of the three culture compartments illustrated in Figure 8a includes a gas-permeable, liquid-impermeable membrane 30 to hold the cultured cells 40, a compartment 10 to hold biological liquid nutrition for the cells, and a rigid, impermeable housing 50. J.A. 1549 (Toner col. 19 ll. 30–35). Inlet port 3 and outlet port 3’ are used to conduct the oxygenated fluid into and out of the common oxygenated fluid compartment 222, where the oxygenated fluid comes into contact with membranes 30, thereby delivering oxygen to the cells. *Id.* (Toner col. 19 ll. 35–37). Inlet port 5 and outlet port 5’ are used for the biological liquid, which is delivered to each culture

compartment via manifold 555 and is removed via manifold 555'. *Id.* (Toner col. 19 ll. 37–43). “Other ports for venting oxygenated fluids may also be added to the impermeable wall 505 of the bioreactor 1.” *Id.* (Toner col. 19 ll. 52–53).

Toner’s Figure 8b illustrates an alternate embodiment, where instead of a common oxygenated fluid compartment 222, each cell culture compartment includes its own separate oxygenated fluid compartment 20:

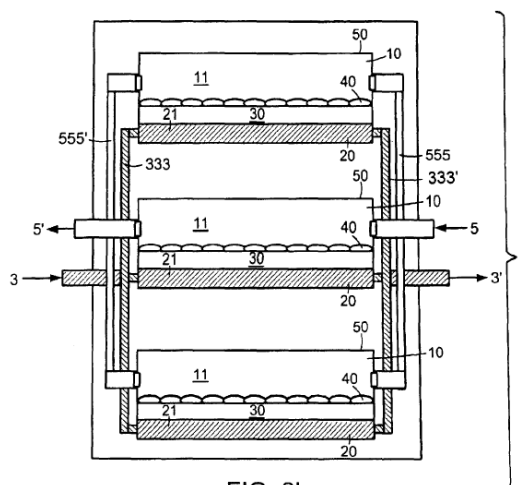

FIG. 8b

J.A. 1527 (Toner Fig. 8b); *see also* J.A. 1549 (Toner col. 19 ll. 56–61).

III. Proceedings Before the Board

On November 25, 2015, Martin requested an interference between the '044 patent and the '267 application under 35 U.S.C. § 135(a).¹ The Patent Trial and Appeal

¹ The Leahy–Smith America Invents Act (“AIA”) eliminated interference proceedings. *See* Pub. L. No. 112–29, § 3, 125 Stat. 284, 285–93 (2011). Because the '044 patent and the '267 application both have effective filing dates prior to March 16, 2013, the effective date of the AIA, they are subject to patent laws in effect prior to the AIA.

Board (“the Board”)² declared the interference on October 31, 2016. Claims 1–45 of the ’044 patent and claims 2–45 of the ’267 application correspond to the interference count.³ J.A. 5.

During the interference, Martin filed a motion with the Board, arguing that claims 1–5, 7–10, 12–14, 16–20, 22–23, 25–26, 28–30, 33–37, 39–42, and 44–45 of the ’044 patent are invalid as anticipated under 35 U.S.C. § 102(b)⁴ by Toner. J.A. 10. In support of its motion, Martin submitted two declarations by its expert, Dr. Crespi. J.A. 13. Wilson opposed Martin’s motion, relying on his own testimony as an expert witness. J.A. 16.

Pre-AIA § 135(a) provided that “[w]hensoever an application is made for a patent which, in the opinion of the Director [of the U.S. Patent and Trademark Office], would interfere with any pending application, or with any unexpired patent, an interference may be declared The Board of Patent Appeals and Interferences shall determine questions of priority of the inventions and may determine questions of patentability.” 35 U.S.C. § 135(a) (2006).

² The AIA renamed the Board of Patent Appeals and Interferences as the Patent Trial and Appeal Board. Pub. L. No. 112–29, § 6, 125 Stat. at 313.

³ Claims 46–49 of the ’044 patent were not part of the interference. Claim 1 of the ’267 application was previously cancelled. These claims are not at issue in this appeal.

⁴ The Pre-AIA version of § 102(b) applies to this appeal. Pre-AIA § 102(b) provided that “[a] person shall be entitled to a patent unless . . . the invention was patented or described in a printed publication in this or a foreign country . . . more than one year prior to the date of the application for patent in the United States.” 35 U.S.C. § 102(b) (2006).

In its motion, Martin proposed a construction for the term “ambient gas,” seeking to limit its meaning to a “gas of the environment surrounding and external to the multi-shelf apparatus.” J.A. 17. Wilson opposed this construction, proposing instead that the term should be construed to mean a “gas that encompasses and contacts the external surfaces of the cell culture device and has a particular set of characteristics.” J.A. 16. The Board did not construe the term, finding that Toner discloses the “ambient gas” limitation under either of the proposed constructions. J.A. 18.

The Board found that Toner’s Figure 8a discloses “multiple ports which communicate between the interior and exterior of the device” and that “would allow for outside air to enter the device.” J.A. 18–19. The Board noted that Toner discloses an oxygenated fluid that “is typically gas and may be ‘air,’” and explained that “[a]ir passing from the exterior of the device into the interior of the device is ‘ambient gas’ under either of the proposed constructions.” J.A. 18. The Board pointed to Dr. Crespi’s testimony, which stated that the presence of additional ports in Toner’s Figure 8a “indicat[ed] ‘that the common gas space inside the device is open to the ambient environment for venting air or the mixture of air with other gases supplied into the gas space via the inlet.’” *Id.* (quoting J.A. 1385 (Crespi Second Decl. ¶ 90)).

The Board rejected Wilson’s argument that Toner does not teach the “ambient gas” limitation because Toner requires the gas to be pumped or forced into the device. The Board explained that Toner’s disclosure of “static, as well as directional, flow of the oxygenated fluid” demonstrates that Toner’s oxygenated fluid does not need to be pumped or forced. *Id.* (citing J.A. 1379–80, 1385 (Crespi Second Decl. ¶¶ 74, 76, 90)). The Board also rejected Wilson’s argument that Toner’s oxygenated fluid is not “ambient gas” because Toner contemplates oxygenated fluid with carefully controlled characteristics different from “those found in standard ambient cell culture conditions.” J.A. 20

(quoting J.A. 658–59 (Wilson Third Opposition at 6:23–7:7, 7:14–8:9)). The Board explained that the claims of the '044 patent do not require the “ambient gas” to have any specific characteristics, but only require “that the gas be ‘ambient.’” *Id.* The Board conceded that Toner does not use the word “ambient,” but explained that Toner nonetheless anticipates this limitation because it is “inherent or otherwise implicit” in Toner. J.A. 19–20 (quoting *Standard Havens Prods., Inc. v. Gencor Indus., Inc.*, 953 F.2d 1360, 1369 (Fed. Cir. 1991) (internal quotation marks omitted)).

The Board also refused to apply judicial estoppel to prevent Martin from asserting that Toner discloses the “ambient gas” limitation, rejecting Wilson’s argument that Martin’s position in this case is inconsistent with statements made by Corning⁵ during prosecution of a parent application to the '267 application. J.A. 20. The Board found that Corning previously argued only that Toner disclosed a “closed oxygen chamber,” not that Toner excluded the presence of “ambient gas.” J.A. 21. The Board further found that Corning “acknowledged that Toner allowed for the flow of oxygenated fluids and [argued] only that these fluids ‘may be’ pressurized.” *Id.* The Board also explained that it based its decision on a different evidentiary record than the one involved in the prior prosecution proceeding, because the Board had before it the testimony of both parties’ experts. *Id.*

On the basis of the above findings, and having further determined that the prior art disclosed the remaining limitations of the claims at issue, the Board issued a decision on Martin’s motion and a judgment on December 26, 2017,

⁵ Corning is the real party in interest behind the '267 application. J.A. 7.

finding claims 1–45 of the '044 patent invalid as anticipated or obvious.⁶ J.A. 2, 22–24.

After the Board's decision, Wilson requested a rehearing, arguing that the Board erred because Toner requires its oxygenated fluid to be sourced from a physically connected gas tank, and because Toner's additional ports only permit the oxygenated fluid to exit from the culture device, not enter it. J.A. 32. The Board denied rehearing, rejecting both arguments. Relying on Dr. Crespi's testimony, the Board found that Toner does not contemplate an external gas tank as the only supply of the oxygenated fluid. J.A. 33–35. The Board further found that the claims of the '044 patent do not require the ambient gas to move from outside of the culture device to its interior, explaining that its decision therefore did not rest on the presence of other ports that permit air to enter the culture device. J.A. 36.

Wilson timely appealed. We have jurisdiction under 28 U.S.C. § 1295(a)(4)(A).

DISCUSSION

Wilson challenges both the Board's conclusions regarding anticipation under 35 U.S.C. § 102(b) and its refusal to apply judicial estoppel. We address each issue in turn.

⁶ The Board found that claims 6, 11, 15, 21, 24, 27, 31–32, 38, and 43 of the '044 patent were obvious under 35 U.S.C. § 103(a) in view of Toner or Toner and other prior art. The Board also invalidated as anticipated or obvious all of the claims of the '267 application on the same bases it invalidated claims 1–45 of the '044 patent, finding that Martin did not rebut the presumption that these claims were invalid in view of the same prior art. J.A. 2; *see* 37 C.F.R. § 41.207(c). These rulings are not at issue in this appeal.

I. Anticipation Under 35 U.S.C. § 102(b)

In interference proceedings, we review the Board's legal conclusions de novo and its factual findings for substantial evidence. *Bd. of Trustees of Leland Stanford Junior Univ. v. Chinese Univ. of Hong Kong*, 860 F.3d 1367, 1375 (Fed. Cir. 2017) (citing *In re Elsner*, 381 F.3d 1125, 1127 (Fed. Cir. 2004) and *In re Gartside*, 203 F.3d 1305, 1313–15 (Fed. Cir. 2000)). Substantial evidence is “such relevant evidence as a reasonable mind might accept as adequate to support a conclusion.” *Gartside*, 203 F.3d at 1312 (quoting *Consol. Edison Co. of N.Y. v. NLRB*, 305 U.S. 197, 229 (1938)). “Where two different conclusions may be warranted based on the evidence of record, the Board's decision to favor one conclusion over the other is the type of decision that must be sustained by this court as supported by substantial evidence.” *In re Bayer Aktiengesellschaft*, 488 F.3d 960, 970 (Fed. Cir. 2007) (citing *In re Jolley*, 308 F.3d 1317, 1329 (Fed. Cir. 2002)).

Anticipation is a question of fact that we review for substantial evidence. *HTC Corp. v. Cellular Commc'ns Equip., LLC*, 877 F.3d 1361, 1368 (Fed. Cir. 2017). For a prior art reference to anticipate, it must disclose all elements of the claim “within the four corners of the document.” *Net MoneyIn, Inc. v. VeriSign, Inc.*, 545 F.3d 1359, 1369 (Fed. Cir. 2008).

Wilson's sole argument concerning anticipation is that Toner does not disclose the “ambient gas” limitation. The Board found that Wilson did not challenge Toner's disclosure of any other limitation. J.A. 15, 32. Thus, resolution of the anticipation issue on appeal turns solely on whether substantial evidence supports the Board's findings that Toner discloses the “ambient gas” limitation. We conclude that it does.

The Board found that Toner discloses using an oxygenated fluid that “is typically gas and may be ‘air,’” and explained that “[a]ir passing from the exterior of the device

into the interior of the device is ‘ambient gas’ under either of the proposed constructions.” J.A. 18 (citing Toner col. 8 ll. 1–9); *see also* J.A. 33. The Board also found that Toner does not require that its oxygenated fluid “be pumped or forced into the device.” J.A. 18, 34. The Board credited Dr. Crespi’s testimony that Toner “allows for static . . . flow of the oxygenated fluid,” which “results in a device having the ‘ambient gas’ limitation of the Wilson claims.” J.A. 18 (citing J.A. 1385 (Crespi Second Decl. ¶ 90)). The Board further pointed to Dr. Crespi’s testimony that Toner’s device “can include ‘[o]ther ports for venting oxygenated fluids’ and the use of static oxygenated fluids indicating ‘that the common gas space inside the device is open to the ambient environment for venting air or the mixture of air with other gases supplied into the gas space via the inlet.’” *Id.* (quoting J.A. 1385 (Crespi Second Decl. ¶ 90) (internal citations omitted)). The Board explained that “these other ports would allow for ambient gas to enter the device.” J.A. 19. The Board found this expert testimony “convincing.” J.A. 15. This is substantial evidence that supports the Board’s findings.

The majority of Wilson’s arguments on appeal concerning anticipation are grounded in its assertion that Toner cannot disclose the “ambient gas” limitation because the oxygenated fluid in Toner must come from a physically connected gas tank. According to Wilson, “every embodiment described in Toner discloses the use of the opposite of ambient gas—gas from a gas tank that has a specific mixture, pressure, and flow rate that can be manipulated or controlled.” Appellant’s Br. 32; *see also id.* at 35–36, 40–43, 45; Reply Br. 22–26. On the basis of this assertion, Wilson argues that the Board’s findings that Toner discloses “ambient gas” are not supported by substantial evidence. We disagree for two reasons.

First, the Board’s findings are supported by Toner’s written description and figures. Toner’s Figure 8a plainly illustrates an embodiment of Toner’s invention without a

connected gas tank. J.A. 1526 (Toner Fig. 8a). Toner's written description of Figure 8a likewise does not include any discussion of a connected gas tank. J.A. 1549 (Toner col. 19 ll. 30–55). In addition, when describing a different embodiment illustrated in Toner's Figure 1, which does include a connected gas tank ("oxygenated fluid source 4"), Toner teaches that the gas tank is only "preferabl[e]"—not required, as Wilson contends. J.A. 1543 (Toner col. 8, ll. 45–49). Thus, Toner's written description and figures support the Board's determination that Toner does not require its oxygenated fluid to be sourced from a gas tank.

Second, Dr. Crespi's testimony, on which the Board relied when it rejected the same argument, supports the Board's findings. Dr. Crespi's testimony states that the culture device in Toner's Figure 8 "is not shown connected to a pressurized air source (i.e., a gas cylinder)." J.A. 1385 (Crespi Second Decl. ¶ 90) (cited by J.A. 18–19, 34–35). Dr. Crespi also testified that the oxygenated fluid inside Toner's device illustrated in Figure 8a can be "static" while the interior of the device is open to the exterior environment via "[o]ther ports for venting oxygenated fluids." J.A. 18 (quoting J.A. 1385 (Crespi Second Decl. ¶ 90) (internal citations omitted)). This suggests that a pressurized gas tank is not required because the pressure inside and outside Toner's device in this embodiment would be the same. Dr. Crespi also explained his opinion as a person of ordinary skill in the art that "the large volume of gas space relative to the cell culture cartridges, pressurized gas flow is not actually needed for the device" illustrated in Toner's Figure 8a. Lastly, in denying rehearing, the Board explained that it also credited Dr. Crespi's deposition testimony "that one skilled in the art would have recognized that the device of Figure 8[a] of Toner could be used as a freestanding device and would not have required the gas tank found in the Figure 1 configuration of Toner." J.A. 35.

Wilson argues that Dr. Crespi's above testimony should not be given any weight. We recognize, however,

that the Board was entitled to weigh and credit that testimony. *Elbit Sys. of Am., LLC v. Thales Visionix, Inc.*, 881 F.3d 1354, 1358 (Fed. Cir. 2018); *see also Inwood Labs., Inc. v. Ives Labs., Inc.*, 456 U.S. 844, 856 (1982) (“Determining the weight and credibility of the evidence is the special province of the trier of fact.”); *Yorkey v. Diab*, 601 F.3d 1279, 1284 (Fed. Cir. 2010) (“We defer to the Board’s findings concerning the credibility of expert witnesses.”). Although Toner’s disclosure of an embodiment that includes a gas tank (illustrated in Toner’s Figure 1) may support a different conclusion than the one reached by the Board, “it is not for us to second-guess the Board’s assessment of the evidence,” but rather “to determine whether substantial evidence supports the conclusion chosen by the Board.” *Velander v. Garner*, 348 F.3d 1359, 1378–79 (Fed. Cir. 2003). Here, the relevant evidence is such that a reasonable mind might accept as adequate to support the Board’s conclusion. *See Fleming v. Escort Inc.*, 774 F.3d 1371, 1375 (Fed. Cir. 2014) (“Substantial evidence is such relevant evidence as reasonable minds might accept as adequate to support a conclusion even if it is possible to draw two inconsistent conclusions from the evidence.” (internal quotation marks and citation omitted)).

Wilson raises other arguments that we find unpersuasive. For example, Wilson argues that it was improper as a matter of law for the Board to rely on Dr. Crespi’s testimony because, according to Wilson, that testimony was extrinsic evidence improperly used “to fill the gaps” in Toner and “to provide missing disclosure.” Appellant’s Br. 39–40. Wilson contends that Dr. Crespi’s testimony “reache[d] beyond the four corners of Toner” by introducing disclosures not found in Toner, such as “the use of a gas pump or fan to circulate gas to the oxygenated fluid compartment,” the presence of a “large volume of gas space relative to the cell culture cartridges,” and “the use of the device of [Toner’s] Figure 8a . . . as a ‘freestanding device.’” *Id.*; Reply Br. 21. On this basis, Wilson argues that Dr. Crespi’s testimony is

not substantial evidence that could support the Board's decisions. See Reply Br. 15.

We have previously explained that “[e]xtrinsic evidence may be used to interpret the allegedly anticipating reference and to shed light on what it would have meant to a person of ordinary skill in the art.” *Monsanto Tech. LLC v. E.I. DuPont de Nemours & Co.*, 878 F.3d 1336, 1345 (Fed. Cir. 2018) (citing *In re Baxter Travenol Labs.*, 952 F.2d 388, 390 (Fed. Cir. 1991)) (internal alterations and quotation marks omitted). The purpose of extrinsic evidence in an anticipation analysis “is to educate the decision-maker to what the reference meant to persons of ordinary skill in the field of the invention, not to fill gaps in the reference.” *Scripps Clinic & Research Found. v. Genentech, Inc.*, 927 F.2d 1565, 1576 (Fed. Cir. 1991), *overruled on other grounds by Abbott Labs. v. Sandoz, Inc.*, 566 F.3d 1282 (Fed. Cir. 2009).

We conclude that that Board did not err by relying on Dr. Crespi's testimony. None of Dr. Crespi's statements to which Wilson directs us introduced elements or limitations claimed in the '044 patent but missing from Toner. Specifically, the claims of the '044 patent do not require “a gas pump or fan” for circulation, “a large volume of gas space relative to the cell culture cartridges,” or a “freestanding device.” Appellant's Br. 39–40; Reply Br. 21. Thus, whether these elements are missing from Toner is irrelevant to the Board's anticipation analysis. See *TF3 Ltd. v. Tre Milano, LLC*, 894 F.3d 1366, 1374 (Fed. Cir. 2018) (“Anticipation requires that all of the *claim elements and their limitations* are shown in a single prior art reference.” (emphasis added) (quoting *In re Skvorecz*, 580 F.3d 1262, 1266 (Fed. Cir. 2009))). Because Dr. Crespi was not attempting to “provide missing disclosure of the claimed invention,” the Board was entitled to rely on his testimony to understand what Toner meant to a person of ordinary skill in the art, which is entirely consistent with our precedent. *Scripps*, 927 F.2d 1565 at 1577.

Wilson next challenges the Board's finding that the "air" disclosed in Toner is the same as "ambient gas" under either of the parties' proposed constructions. Appellant's Br. 41–43 (citing J.A. 18, 33). Wilson asserts that the air disclosed in Toner is "always supplied under pressure, from a physically connected source of gas." *Id.* at 41; *see also id.* at 43. According to Wilson, such air would therefore not meet the "ambient gas" limitation under its proposed construction because "it would not have the same 'particular set of characteristics' as the 'gas that encompasses and contacts the external surfaces of the cell culture device.'" *Id.* at 42. This argument fails because it also relies on the erroneous assumption that Toner requires the use of a gas tank. In addition, the Board's finding is supported by Dr. Crespi's testimony, which states that based on Toner's disclosure of using air as the oxygenated fluid, "the gas inside the common gas space (222), delivered via the inlet (3), would be the same as the ambient gas (i.e., air . . .)." J.A. 1385 (Crespi Second Decl. ¶ 90) (cited by J.A. 18). Wilson also concedes that Toner does not require any specific location from which its air must originate (and neither do the claims of the '044 patent). *Id.* Thus, even if a gas tank were required, it could be filled with the air outside the culture device, thereby ensuring that the air in the tank had the same "particular set of characteristics." *See id.*

Wilson also contends that the air disclosed in Toner does not meet the "ambient gas" limitation under Martin's proposed construction either, because the air does not originate from the "immediately surrounding environment" of the culture device. *Id.* This argument is misplaced because Martin's proposed construction only requires the air to originate from the "environment surrounding and external" to the culture device. J.A. 17. There is no requirement that the air originates from the *immediately* surrounding environment.

Lastly, Wilson argues that the Board's finding that gas may enter from the exterior of Toner's device through

“other ports” is not supported by substantial evidence because these ports only permit the oxygenated fluid inside the device to exit. Appellant’s Br. 46–47. The Board clarified in its decision denying rehearing, however, that its prior decision did not indicate that “ambient gas must move from the exterior of the device to the interior of the device” through these “other ports.” J.A. 36. Rather, as the Board explained, ambient gas only had to “resid[e] within each gas space.” *Id.* Dr. Crespi’s testimony likewise states that Toner’s oxygenated fluid is “supplied into the gas space via the inlet.” J.A. 1385 (Crespi Second Decl. ¶ 90). Thus, even if Wilson is correct that Toner’s “other ports” do not permit “ambient gas” to enter its device, that does not alter our conclusion that the Board’s findings are supported by substantial evidence.

We conclude that substantial evidence supports the Board’s final determination that Toner discloses the “ambient gas” limitation.

II. Judicial Estoppel

The doctrine of judicial estoppel provides that “where a party successfully urges a particular position in a legal proceeding, it is estopped from taking a contrary position in a subsequent proceeding where its interests have changed.” *Data Gen. Corp. v. Johnson*, 78 F.3d 1556, 1565 (Fed. Cir. 1996) (citing *Davis v. Wakelee*, 156 U.S. 680, 689 (1895)). The Board has authority and discretion to apply the doctrine of judicial estoppel. *Id.*; see *New Hampshire v. Maine*, 532 U.S. 742, 750 (2001) (“[J]udicial estoppel is an equitable doctrine invoked by a court at its discretion.” (internal quotation marks omitted)). To decide whether to apply judicial estoppel, courts typically consider several factors, including (1) whether a party’s later position is “clearly inconsistent” with its earlier position; (2) whether a court has accepted the party’s prior position, such that accepting its “inconsistent position in a later proceeding would create the perception that either the first or the second court was

misled”; and (3) whether the party changing its position “would derive an unfair advantage or impose an unfair detriment on the opposing party if not estopped.” *New Hampshire*, 532 U.S. at 751 (internal quotation marks and citations omitted). “Additional considerations may inform the doctrine’s application in specific factual contexts.” *Id.*

We review the Board’s refusal to apply the doctrine for abuse of discretion. *Id.* The Board abuses its discretion when it makes “a clear error of judgment in weighing the relevant factors” or bases its decision “on an error of law or clearly erroneous factual findings.” *ArcelorMittal Atlantique et Lorraine v. AK Steel Corp.*, 908 F.3d 1267, 1277 (Fed. Cir. 2018).

Wilson argues on appeal that the Board abused its discretion by refusing to judicially estop Martin from arguing that Toner discloses the “ambient gas” limitation. Wilson contends that application of the judicial estoppel doctrine was warranted in this case because during prior prosecution of a parent application to the ’267 application, Corning, the real party in interest behind Martin, made statements that allegedly are inconsistent with Martin’s position in this case. Specifically, Wilson points to Corning’s response to a non-final rejection of its prior application, in which Corning stated that “Toner discloses a ‘closed oxygen chamber’” that permits “users [to] ‘control and manipulate’ the gas delivered to the device,” and argues that a closed oxygen chamber cannot be open to “ambient gas.” Appellant’s Br. 19. Wilson further asserts that accepting Martin’s current position that Toner discloses “ambient gas” would lead to the perception that “either the patent examiner or the Board was misled,” and would provide an unfair advantage to Corning. Appellant’s Br. 24 (capitalization removed). We disagree for two reasons.

First, Corning’s statements to which Wilson directs us were made with respect to a different embodiment of Toner’s invention than the one on which the Board relied

in this case. Specifically, the Examiner rejected Corning's prior application as anticipated by Toner's Figure 8b—not Figure 8a. See J.A. 2922. This difference is significant because Toner's Figure 8b illustrates an embodiment in which each cell culture compartment has its own separate oxygenated fluid compartment, and the interior of the cell culture device itself is closed off from the external environment. See J.A. 1527 (Toner Fig. 8b); J.A. 1549 (Toner col. 19 ll. 56–61). By contrast, Figure 8a—the figure on which Martin and the Board relied in this case—illustrates an embodiment that includes a common oxygenated fluid compartment with inlet and outlet ports open to the external environment. Thus, Corning's prior statements that Toner's Figure 8b illustrated a “closed oxygen chamber” are not inconsistent with Martin's current position that Toner's Figure 8a discloses an open oxygen chamber that contains “ambient gas.”

Wilson attempts to overcome this flaw in its argument by asserting that the Examiner cited to both Figures 8a and 8b in rejecting Corning's prior application on obviousness grounds. Reply Br. 10 (citing J.A. 2923–24). According to Wilson, Corning's statements therefore “must also be interpreted as being directed to Toner in general, including Figure 8a.” *Id.* The Examiner only cited Figure 8a, however, as support for Toner's disclosure that its cell culture compartments “are separated slightly in the apparatus.” J.A. 2924. Because this disclosure has no connection to Toner's disclosure of oxygenated fluid compartments in either figure, Corning's statements were plainly not directed to Toner's Figure 8a.

Second, we agree with the Board that Martin's current position is not clearly inconsistent with Corning's prior statements because those statements were made in a different context and were part of a different evidentiary record. Specifically, the claims in Corning's prior application were directed to structural components of the cell culture compartment, instead of cell culture conditions like the

presence of “ambient gas.” *See* J.A. 21, 37, 2928, 2955. The claims of Corning’s prior application also did not include the “ambient gas” limitation. Lastly, the Examiner reviewing Corning’s prior application did not have the benefit of Dr. Crespi’s testimony. We have previously refused to apply judicial estoppel in circumstances where the contexts surrounding a party’s allegedly inconsistent positions were markedly different. *See Akamai Tech. v. Limelight Networks, Inc.*, 805 F.3d 1368, 1378 (Fed. Cir. 2015). On this record, where the context and record in the prior proceeding is likewise markedly different from this case, we conclude that the Board did not abuse its discretion by refusing to apply judicial estoppel.

CONCLUSION

We have considered Wilson’s remaining arguments and find them unpersuasive. We conclude that the Board’s findings that Toner discloses the “ambient gas” limitation and therefore anticipates claims 1–5, 7–10, 12–14, 16–20, 22, 23, 25, 26, 28–30, 33–37, 39–42, 44, and 45 of the ’044 patent are supported by substantial evidence. We further conclude that the Board did not abuse its discretion by refusing to apply judicial estoppel. We therefore *affirm* the Board’s order and decisions cancelling claims 1–45 of the ’044 patent and claims 2–45 of the ’267 application.

AFFIRMED

COSTS

Costs to Martin.