

NOTE: This disposition is nonprecedential.

**United States Court of Appeals
for the Federal Circuit**

IN RE: STEVEN C. CHUDIK,
Appellant

2016-2673

Appeal from the United States Patent and Trademark
Office, Patent Trial and Appeal Board in No. 13/068,309.

Decided: August 25, 2017

ERIC RYAN WALTMIRE, Erickson Law Group, PC,
Wheaton, IL, argued for appellant. Also represented by
GREGORY B. BEGGS, Law Offices of Gregory B. Beggs,
Downers Grove, IL.

MEREDITH HOPE SCHOENFELD, Office of the Solicitor,
United States Patent and Trademark Office, Alexandria,
VA, argued for appellee Joseph Matal. Also represented
by NATHAN K. KELLEY, AMY J. NELSON, THOMAS W.
KRAUSE.

Before LOURIE, MOORE, and HUGHES, *Circuit Judges*.
HUGHES, *Circuit Judge*.

Dr. Steven Chudik appeals from the Patent Trial and Appeal Board's determination that claims 5–15 of U.S. Patent Application 13/068,309 are not patentable over the prior art. Because substantial evidence supports the Board's determination, we affirm.

I

The '309 application is directed to a humeral implant used in shoulder replacement surgery. The specification, as shown in Figure 16 below, discloses a humeral implant having a humeral surface 96 that is shaped to match the anatomy of the humeral head, while stem 98 engages the side facing away from the glenoid cavity.

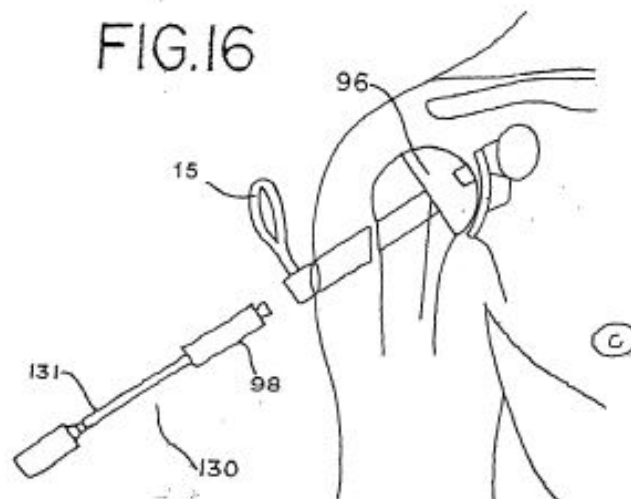

Independent claim 5 reads as follows:

5. A humeral implant comprising a humeral surface component having a non-articular surface configured for long-lasting fixation of the implant on a humeral head and no stem.

The Examiner rejected claim 5 under 35 U.S.C. § 102(b) as anticipated by Leonard (French Patent Pub.

No. 2825263), and the Board affirmed the Examiner. Dr. Chudik appeals from the Board's decision. We have jurisdiction under 28 U.S.C. § 1295(a)(4)(A).

II

Because Dr. Chudik's arguments for the patentability of dependent claims 6–15 depends on claim 5, we address only claim 5. We review the Board's legal conclusions de novo and its factual findings for substantial evidence. *Rambus Inc. v. Rea*, 731 F.3d 1248, 1251 (Fed. Cir. 2013). Dr. Chudik first challenges the Board's finding that Leonard discloses the "no stem" limitation of claim 5. Leonard discloses shoulder implants for attachment in the glenoid cavity. In one embodiment, as depicted in Figures 3A and 5 below, the implant comprises a platen 24 with portion 40 that is placed between a base 20 and the head of the humerus 12.

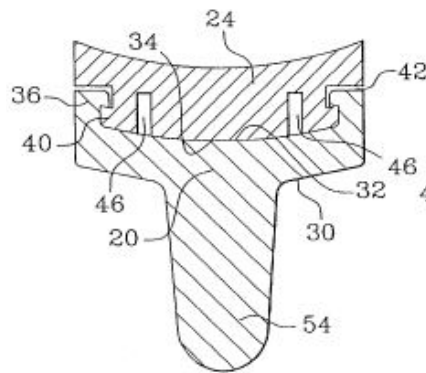

Fig. 3A

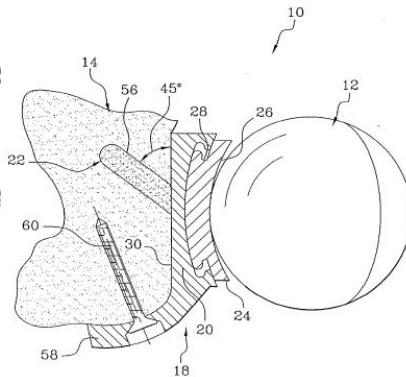

Fig. 5

According to Dr. Chudik, portion 40 in Leonard is a "stem" because it extends away from the main body of platen 24. We disagree. The '309 specification describes the stem as a physically distinct and separate component from the implant. J.A. 249 ¶ 155. In Leonard, portion 40 is a part of and not separate from platen 24. Therefore,

the Board did not err in finding that Leonard discloses the “no stem” limitation of claim 5.

Next, Dr. Chudik argues that Leonard does not disclose a “non-articular surface configured for long-lasting fixation” as required by claim 5. Dr. Chudik contends that Leonard discloses a sliding contact between the humeral head and the platen, and that using screws and cements to achieve “long-lasting fixation” would change the structure of Leonard. Contrary to Dr. Chudik’s argument, claim 5 requires only a non-articular surface that is *configured for* long-lasting fixation. As a result, whether Leonard discusses a sliding contact is not relevant to whether Leonard is capable of long-lasting fixation. Dr. Chudik has not pointed to any evidence in the record that Leonard is incapable of long-lasting fixation. He also argues that using screws and cements to achieve long-lasting fixation would result in a joint with a limited range of motion—but claim 5 contains no limitation regarding range of motion. Therefore, substantial evidence supports the Board’s conclusion.

Finally, Dr. Chudik argues that Leonard does not disclose the “humeral implant” limitation of claim 5 because Leonard is directed to a glenoid implant and not a humeral implant. The patentability of an apparatus claim “depends on the claimed structure, not on the use or purpose of that structure.” *Catalina Mktg. Int’l v. Coolsavings.com, Inc.*, 289 F.3d 801, 809 (Fed. Cir. 2002); *see also In re Schreiber*, 128 F.3d 1473, 1477 (Fed. Cir. 1997) (“It is well settled that the recitation of a new intended use for an old product does not make a claim to that old product patentable.”) Thus, Dr. Chudik’s contention that his apparatus will be used in a humeral, as opposed to a glenoid, implant is not a patentable distinction, and cannot prevent Leonard from anticipating the claim.

We have considered Dr. Chudik's remaining arguments but find them unpersuasive. Because the Board applied the correct law and because its decision is supported by substantial evidence, we affirm the Board's decision.

AFFIRMED

No costs.