

**United States Court of Appeals  
for the Federal Circuit**

---

**DSS TECHNOLOGY MANAGEMENT, INC.,**  
*Appellant*

v.

**APPLE INC.,**  
*Appellee*

---

2016-2523, 2016-2524

---

Appeals from the United States Patent and Trade-  
mark Office, Patent Trial and Appeal Board in Nos.  
IPR2015-00369, IPR2015-00373.

---

Decided: March 23, 2018

---

ERIC WILLIAM BUETHER, Buether Joe & Carpenter  
LLC, Dallas, TX, argued for appellant. Also represented  
by BRIAN ANDREW CARPENTER; ANDRIY LYTVYN, Smith &  
Hopen, PA, Oldsmar, FL.

JON WRIGHT, Sterne Kessler Goldstein & Fox, PLLC,  
Washington, DC, argued for appellee. Also represented  
by DAVID K.S. CORNWELL, JASON A. FITZSIMMONS.

---

Before NEWMAN, O'MALLEY, and REYNA, *Circuit Judges*.

Opinion for the court filed by *Circuit Judge O'MALLEY*.

Dissenting opinion filed by *Circuit Judge NEWMAN*.

O'MALLEY, *Circuit Judge*.

In response to two petitions for *inter partes* review filed by Appellee Apple Inc. (“Apple”), the Patent Trial and Appeal Board (“Board”) issued a pair of final written decisions finding claims 1–4 and 9–10 of U.S. Patent No. 6,128,290 (“the ’290 patent”), owned by Appellant DSS Technology Management, Inc. (“DSS”), unpatentable as obvious. *Apple Inc. v. DSS Tech. Mgmt., Inc.*, No. IPR2015-00369, 2016 WL 3382361 (P.T.A.B. June 17, 2016) (*Apple I*); *Apple Inc. v. DSS Tech. Mgmt., Inc.*, No. IPR2015-00373, 2016 WL 3382464 (P.T.A.B. June 17, 2016) (*Apple II*). Because we find that the Board did not provide a sufficient explanation for its conclusions, and because we cannot glean any such explanation from the record, we reverse.

## I. BACKGROUND

### A. The ’290 patent

The ’290 patent, which issued in 2000 and is assigned to DSS, is directed to a wireless communication network for a single host device and multiple peripheral devices. The ’290 patent discloses a data network for bidirectional wireless data communications between a host or server microcomputer—described in the specification as a personal digital assistant or “PDA”—and a plurality of peripheral devices that the specification refers to as personal electronic accessories or “PEAs.” ’290 patent, col. 1, ll. 11–20, col. 2, ll. 15–18. According to the ’290 patent, this data network provides “highly reliable” communication, “requires extremely low power consumption, particularly for the peripheral units,” “avoids interference from nearby similar systems,” and “is of relatively simple and inexpensive construction.” *Id.* at col. 1, ll. 33–

47. Figure 1 of the '290 patent illustrates an embodiment of this wireless data network:

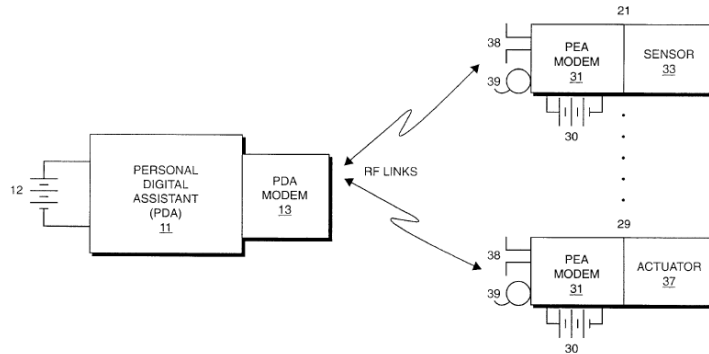

FIG. 1

*Id.* at Fig. 1. This figure depicts a server microcomputer, shown as PDA **11**, and a plurality of peripheral units **21** to **29**. *Id.* at col. 2, ll. 42–44, col. 2, l. 66–col. 3, l. 15.

The '290 patent teaches that the transmitters within the host or server microcomputer and the peripheral units in the data network operate in a “low duty cycle pulsed mode of operation.” *Id.* at col. 1, ll. 57–59. In such a mode of operation, each peripheral unit is allocated a subset of available time slots in which it receives or transmits data from or to the server microcomputer in radio frequency (i.e., wireless) bursts. *Id.* at col. 3, l. 57–col. 4, l. 6. These time slots are determined in relation to synchronizing information initially transmitted from the server microcomputer. *Id.* at col. 2, ll. 35–39. In the time slots when a peripheral unit is neither receiving nor transmitting, its reception and transmission circuitry may be powered down. *Id.* at col. 4, ll. 6–8. “The low duty cycle pulsed operation both substantially reduces power consumption and facilitates the rejection of interfering signals.” *Id.* at col. 1, ll. 59–61.

The '290 patent contains 11 apparatus claims, six of which—claims 1–4 and 9–10—are relevant to this appeal.

Because the parties dispute only a single claim limitation recited in independent claim 1, they agree that claim 1 is representative. Claim 1 recites:

A data network system for effecting coordinated operation of a plurality of electronic devices, said system comprising:

a server microcomputer unit;

a plurality of peripheral units which are battery powered and portable, which provide either input information from the user or output information to the user, and which are adapted to operate within short range of said server unit;

said server microcomputer incorporating an RF [radio frequency] transmitter for sending commands and synchronizing information to said peripheral units;

said peripheral units each including an RF receiver for detecting said commands and synchronizing information and including also an RF transmitter for sending input information from the user to said server microcomputer;

said server microcomputer including a receiver for receiving input information transmitted from said peripheral units;

*said server and peripheral transmitters being energized in low duty cycle RF bursts at intervals determined by a code sequence which is timed in relation to said synchronizing information.*

'290 patent, col. 11, l. 62–col. 12, l. 18 (emphasis added).

The only disputed limitation of claim 1 pertains to the “low duty cycle RF bursts” referenced above. Claim 1 requires both the server microcomputer and each of the peripheral units to comprise transmitters. According to

the claim, the server microcomputer's transmitter is used "for sending commands and synchronizing information to said peripheral units," while the peripheral unit's transmitters are used "for sending input information from the user to said server microcomputer." *Id.* at col. 12, ll. 4–11. The transmitters on both the server microcomputer and the peripheral units must be "energized in low duty cycle RF bursts." *Id.* at col. 12, ll. 15–18. This limitation was the focus of the IPR proceedings below, and it is at the center of the single dispute on appeal.

### B. Relevant Prior Art

The Board relied on two pieces of prior art in the IPR proceedings: U.S. Patent No. 5,241,542 to Natarajan et al. ("Natarajan"), and U.S. Patent No. 4,887,266 to Neve et al. ("Neve"). In its final written decisions, the Board found that the combination of Natarajan and Neve rendered obvious all of the challenged claims of the '290 patent. *Apple I*, 2016 WL 3382361, at \*1, \*19; *Apple II*, 2016 WL 3382464, at \*1, \*19. Of the two prior art references, only Natarajan is relevant to this appeal.

As the Board described it, "Natarajan is directed to power conservation in wireless communication, particularly battery efficient operation of wireless link adapters of mobile computers (also referred to, *inter alia*, as battery powered computers, hand held or laptop computers, mobile units, and mobile stations) as controlled by multi-access protocols used in wireless communication." *Apple I*, 2016 WL 3382361, at \*8. Figure 2 of Natarajan depicts this system:

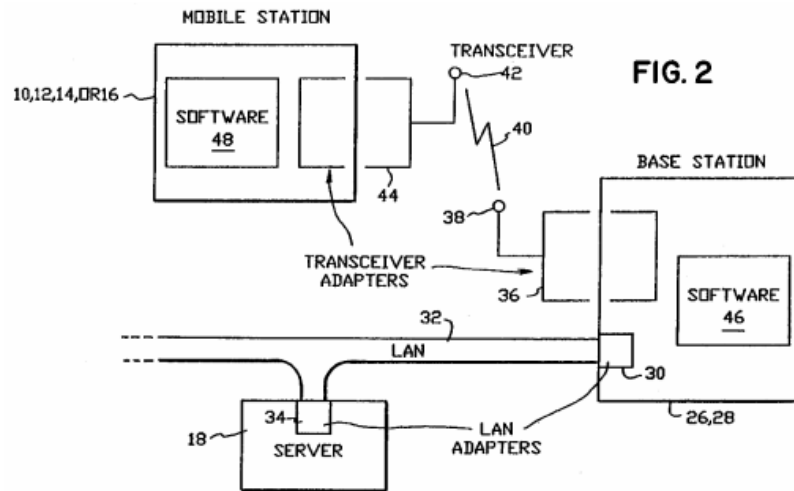

Natarajan, Fig. 2. This block diagram shows mobile stations 10, 12, 14, and 16, which communicate via wireless transceivers within transceiver adapters 44 and 36 with base stations 26 and 28, which are in turn connected to server 18. *Id.* at col. 2, ll. 32–39, 51–52, 58–59, 65–67.

According to Natarajan, “the main idea for minimizing battery power consumed by wireless link adapters at the mobile units” depends on the “scheduled access multi-access protocol” through which the mobile units communicate with the base station. *Id.* at col. 3, l. 59–col. 4, l. 6, col. 4, ll. 20–23. These protocols “can be implemented to effectively conserve battery power by suitable control of the state of transmitter and receiver units at the portable units (i.e., by scheduling when they should be turned ON or OFF).” *Id.* at col. 3, l. 66–col. 4, l. 3. “A desirable solution is one in which the transmitter (or receiver) consumes power only when it is actively transmitting a message (or actively receiving a message).” *Id.* at col. 4, ll. 3–6.

Natarajan’s scheduled multi-access protocol achieves this goal by dividing time into fixed-length frames, which

are themselves divided into slots. *Id.* at col. 4, ll. 20–23. Figure 4 of Natarajan shows an exemplary frame:

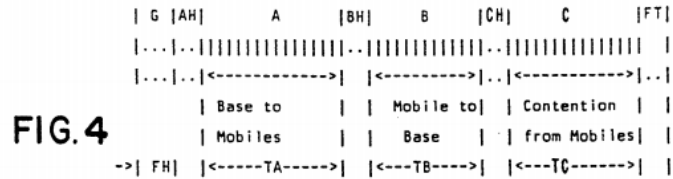

*Id.*, Fig. 4.

The frame is divided into three subframes: A, B, and C. *Id.* at col. 4, ll. 28–38. The first subframe, period A, is used “for broadcast of [data] packets from base station to mobile units (outbound traffic).” *Id.* at col. 4, ll. 30–32. The second subframe, period B, is used for “contention-free transfer of all traffic from mobile units to base station (inbound traffic).” *Id.* at col. 4, ll. 33–35. The third subframe, period C, is “for the transfer of all bursty data traffic in a contention mode from mobile units to base station (inbound traffic).” *Id.* at col. 4, ll. 36–38. Each of subframes A and B in this example is associated with a header, AH and BH, respectively, that is broadcast by the base station to all mobile stations at the start of the subframe. *Id.* at col. 4, ll. 30–35. Using these headers, each mobile unit can compute exactly when it should be ready to receive data from the base station and when it should begin transmitting data to the base station. *Id.* at col. 4, l. 67–col. 5, l. 2; *id.* at col. 5, ll. 20–22. The mobile unit can turn its receiver or transmitter off to save power during those time slots in which the mobile unit is not receiving or transmitting data. *Id.* at col. 5, ll. 2–6, 23–29.

### C. Procedural History

Apple concurrently filed two IPR petitions related to the '290 patent on December 4, 2014. Apple’s first petition challenged the validity of claims 1–4 of the '290 patent, and the second challenged the validity of claims 6, 7, 9, and 10. The Board instituted two IPRs on June 25,

2015, as IPR2015-00369 and IPR2015-00373, respectively. It instituted the first IPR to determine whether claims 1 to 4 were obvious over Natarajan and Neve. The Board instituted the second IPR on the same basis, as well as on the ground that claims 6 and 7 allegedly were obvious over U.S. Patent No. 5,696,903 to Mahany. DSS later disclaimed claims 6 and 7 of the '290 patent.

The Board issued its final written decisions in both IPRs on June 17, 2016. The Board found that all remaining challenged claims—claims 1–4, 9, and 10—were invalid as obvious over Natarajan in view of Neve. *Apple I*, 2016 WL 3382361, at \*1, \*19; *Apple II*, 2016 WL 3382464, at \*1, \*19.<sup>1</sup> DSS conceded that all but one limitation in each of these claims was disclosed in Natarajan and Neve. *Apple I*, 2016 WL 3382361, at \*10–11. But DSS disputed that either reference disclosed the limitation “said server . . . transmitter[] being energized in low duty cycle RF bursts.” *Id.* at \*11.

The Board construed the term “energized in low duty cycle RF bursts” as “energized, in short periods of intense RF transmission activity on an otherwise quiet data channel, only to the extent required to satisfy the data transmission needs over the course of a communication cycle.” *Id.* at \*4–7. The Board explained that it “underst[oo]d the ‘duty cycle’ of a transmitter to be the average ratio of the durations during which the transmitter is energized to the [total] duration of communication cycles over the course of network operation.” *Id.* at \*6.

The Board then turned to the question of obviousness. Apple argued that, because the mobile unit transmitters in Natarajan operated in “low duty cycle RF bursts,” “it

---

<sup>1</sup> The two final written decisions are identical in all relevant respects. We hereafter cite only to the first final written decision for simplicity.



would have been plainly obvious to a [person of ordinary skill in the art] to have the base station operate in an analogous manner.” *Id.* at \*13 (alteration in original). Apple explained that, because the “low duty cycle RF bursts” limitation was not novel and because “the base and mobile stations have the same physical structure,” it “would have been no more than using a known technique to improve similar devices in the same way.” *Id.*

Although DSS admitted that Natarajan discloses a system for reducing power consumption in mobile units, DSS argued that Natarajan says nothing about doing the same for the *base station* transmitter. *Id.* at \*12. DSS noted that the stated goal of the Natarajan reference is to provide energy savings for the mobile units, not the base station. *Id.* DSS also observed that the base station in Natarajan uses a different communications scheme than the mobile units, where the base station transmits continuously during the time slots designated for outbound traffic and cannot be turned off at any point during that period. *Id.*

The Board was “persuaded by each of Apple’s arguments presented above.” *Id.* at \*15. It found that “Natarajan is expressly concerned with ‘power conservation due to wireless communication,’ and specifically, with ‘battery efficient operation of wireless link adapters of mobile computers as controlled by multiaccess protocols used in wireless communication.’” *Id.* (quoting Natarajan, col. 1, ll. 7–13). The Board acknowledged that Natarajan describes only the mobile units as battery-powered devices, but it noted that the base units also are conventional microcomputers and contain similar wireless communication components as the mobile units. *Id.* (citing Natarajan, col. 2, ll. 40–41, col. 2, l. 51–col. 3, l. 2).

From this, the Board concluded “that a person of ordinary skill in the art would have been motivated by Natarajan to apply the same power-conserving techniques to

base units as it is disclosed with respect to mobile units, as well as that it would have been within the skill of the ordinarily skilled artisan to do so.” *Id.* The PTAB found “no persuasive evidence of record that it would have been ‘uniquely challenging or difficult for one of ordinary skill in the art’ to do so.” *Id.* (quoting *Leapfrog Enters., Inc. v. Fisher-Price, Inc.*, 485 F.3d 1157, 1162 (Fed. Cir. 2007)). The Board noted that, “as the [Supreme] Court explained in *KSR*, the skilled artisan is ‘a person of ordinary creativity, not an automaton.’” *Id.* (quoting *KSR Int’l Co. v. Teleflex Inc.*, 550 U.S. 398, 420–21 (2007)).

DSS appeals this single aspect of the Board’s decisions. We have jurisdiction over this appeal under 28 U.S.C. § 1295(a)(4). See *Shaw Indus. Grp., Inc. v. Automated Creel Sys., Inc.*, 817 F.3d 1293, 1297 (Fed. Cir. 2016).

## II. DISCUSSION

“Obviousness is a question of law based on underlying findings of fact.” *In re Kubin*, 561 F.3d 1351, 1355 (Fed. Cir. 2009). We review the factual findings underlying the Board’s obviousness determination for substantial evidence, whereas we review its legal conclusions *de novo*. *In re Gartside*, 203 F.3d 1305, 1316 (Fed. Cir. 2000).

A patent is obvious “if the differences between the subject matter sought to be patented and the prior art are such that the subject matter as a whole would have been obvious at the time the invention was made to a person having ordinary skill in the art to which said subject matter pertains.” 35 U.S.C. § 103(a). “Though less common, in appropriate circumstances, a patent can be obvious in light of a single prior art reference if it would have been obvious to modify that reference to arrive at the patented invention.” *Arendi S.A.R.L. v. Apple Inc.*, 832 F.3d 1355, 1361 (Fed. Cir. 2016) (citations omitted).

The sole issue on appeal is the Board’s finding that it would have been obvious to modify the base station transmitter in Natarajan to be “energized in low duty cycle RF bursts,” as required by the claims of the ’290 patent. *Apple I*, 2016 WL 3382361, at \*15.<sup>2</sup> We hold that the Board’s final written decisions fail to provide sufficient explanation for its obviousness finding.

As we observed in *Arendi*, “common sense and common knowledge have their proper place in the obviousness inquiry,” at least “if explained with sufficient reasoning.” 832 F.3d at 1361 (quoting *Perfect Web Techs., Inc. v. InfoUSA, Inc.*, 587 F.3d 1324, 1328 (Fed. Cir. 2009)). “But,” we cautioned, “there are at least three caveats to note in applying ‘common sense’ in an obviousness analysis.” *Id.* “First, common sense is typically invoked to provide a known *motivation to combine*, not to supply a missing claim limitation.” *Id.* at 1361–62 (citing *DyStar Textilfarben GmbH & Co. Deutschland KG v. C.H. Patrick Co.*, 464 F.3d 1356, 1360, 1368, 1371 (Fed. Cir. 2006), and *Randall Mfg. v. Rea*, 733 F.3d 1355, 1356, 1363 (Fed. Cir. 2013)). Second, we have invoked common sense to fill in a *missing* limitation only when “the limitation in question was unusually simple and the technology particularly straightforward.” *Id.* at 1362 (citing *Perfect Web*, 587 F.3d at 1326). “Third, our cases repeatedly warn that references to ‘common sense’—whether to supply a motivation to combine or a missing limitation—cannot be used as a wholesale substitute for reasoned analysis and evidentiary support, especially when dealing with a limitation missing from the prior art references specified.” *Id.*

---

<sup>2</sup> Apple admits that the Board did not adopt Apple’s argument that Natarajan *expressly* discloses a server transmitter energized in low duty cycle RF bursts. Appellee’s Br. 29. Apple has not cross-appealed this issue.

The Board’s invocation of “ordinary creativity” is no different from the reference to “common sense” that we considered in *Arendi*. *See id.* at 1361 (noting that the obviousness analysis should take into account “the knowledge, creativity, and common sense that an ordinarily skilled artisan would have brought to bear when considering combinations or modifications” (quoting *Randall*, 733 F.3d at 1362)). Here, the Board relied on a gap-filler—“ordinary creativity” instead of “common sense”—to supply a missing claim limitation. *Id.* at 1361. “In cases in which ‘common sense’ is used to supply a missing limitation, as distinct from a motivation to combine, . . . our search for a reasoned basis for resort to common sense must be searching.” *Id.* at 1363. The Board’s reliance on “ordinary creativity” calls for the same “searching” inquiry.

As in *Arendi*, the limitation at issue here is not “unusually simple,” and the technology is not “particularly straightforward.” *Id.* at 1362. The ’290 patent devotes the bulk of its written description to the complex communications protocol that enables the claimed “low duty cycle” mode of operation. ’290 patent, col. 5, l. 46–col. 11, l. 52. As the Board’s claim construction discussion demonstrates, the question of whether a transmitter is “energized in low duty cycle RF bursts” is not an easy one. *Apple I*, 2016 WL 3382361, at \*4–7. The missing limitation, moreover, “plays a major role in the subject matter claimed.” *Arendi*, 832 F.3d at 1362. Unlike the Natarajan reference, the ’290 patent contemplates a server that is *itself* a mobile device, and a stated object of the patent is for this server to have “extremely low power consumption.” ’290 patent, Fig. 1, col. 1, ll. 33–47. The ’290 patent explains that the low duty cycle pulsed mode of operation is critical to achieving this goal. *Id.* at col. 1:59–61.

With these precepts in mind, we find that the Board’s decisions do not satisfy the standard set forth in *Arendi*.

The full extent of the Board’s analysis is contained in a single paragraph. *Apple I*, 2016 WL 3382361, at \*15. After acknowledging that Natarajan does not disclose a base unit transmitter that uses the same power conservation technique, the Board concluded that a person of ordinary skill would have been motivated to modify Natarajan to incorporate such a technique into a base unit transmitter and that such a modification would have been within the skill of the ordinarily skilled artisan. *Id.* In reaching these conclusions, the Board made no further citation to the record. *Id.* It referred instead to the “ordinary creativity” of the skilled artisan. *Id.* (quoting *KSR*, 550 U.S. at 420–21). This is not enough to satisfy the *Arendi* standard.

Apple argues that this characterization of the Board’s analysis ignores the previous eight pages of discussion. Those pages, however, are devoted solely to enumerating the parties’ arguments. Even if we assume that the Board incorporated any or all of Apple’s arguments by reference by stating that it was “persuaded by each of Apple’s arguments presented above,” *id.*, only one paragraph of the Board’s summary of Apple’s arguments is relevant to the Board’s obviousness conclusion. This paragraph quotes Apple’s argument that “it would have been plainly obvious to a [person of ordinary skill in the art] to have the base station operate in an analogous manner” to the mobile units. *Id.* at \*13 (alteration in original). The Board also repeated Apple’s assertion that, “[b]ecause the base and mobile stations have the same physical structure, this would have been no more than using a known technique to improve similar devices in the same way.” *Id.* (alteration in original).

The Board parenthetically noted the evidence that Apple cited in support of these contentions, which consisted solely of paragraphs of a declaration from Apple’s

expert, Dr. Hu.<sup>3</sup> She opined that “it would have been obvious to a [person of ordinary skill in the art] to have the base station [in Natarajan] operate in an analogous manner” to the mobile units, which the parties agreed operated in “low duty cycle RF bursts.” J.A. 1994, ¶ 45. She noted that “[t]he RF systems of the base station and mobile stations in Natarajan have the same physical structure.” *Id.* (citing Natarajan, col. 3, ll. 7–8, Fig. 3). She then explained that a person of skill in the art “applying the exact design disclosed in Natarajan to an application exactly as described in Natarajan,” where most users are likely to be inactive most of the time, “would have conceived a system in which . . . the transmitter and the receiver of the base station . . . operate in ‘low duty cycle RF bursts.’” *Id.* (citing Natarajan, col. 6, ll. 41–44). Dr. Hu therefore concluded that a person of skill in the art would not have found the “low duty cycle RF bursts” limitation to be “novel.” *Id.*

To the extent the Board’s obviousness findings were based on Dr. Hu’s testimony—which is questionable, because the Board never cited her testimony directly—her “conclusory statements and unspecific expert testimony” are insufficient to support the Board’s findings. *Arendi*, 832 F.3d at 1366; *see also Icon Health & Fitness, Inc. v. Strava, Inc.*, 849 F.3d 1034, 1047 (Fed. Cir. 2017) (“[T]he

---

<sup>3</sup> We note DSS’s contention that Apple did not present this expert declaration with its initial petition for *inter partes* review. **[Reply 24–26.]** Because DSS has not appealed the Board’s reliance on this evidence, however, we do not decide whether this violated the applicable statutes and rules. *See Intelligent Bio-Systems, Inc. v. Illumina Cambridge Ltd.*, 821 F.3d 1359, 1369–70 (Fed. Cir. 2016) (affirming the Board’s refusal to consider an argument “raised for the first time in [an IPR petitioner’s] reply brief and expert declaration”).

[Board] is permitted to credit a party's argument as part of its reasoned explanation of its factual findings; however, the [Board] must 'explain[] why [it] accepts the prevailing argument.'" (alterations in original) (quoting *In re NuVasive, Inc.*, 842 F.3d 1376, 1383 (Fed. Cir. 2016)).<sup>4</sup> Dr. Hu and the Board failed to consider that Natarajan's multi-access protocol imposes different transmission requirements on the base station and the mobile units. In the only exemplary embodiment in Natarajan, as DSS points out, the base station allocates transmission time slots for a mobile unit only if the base station has data to transmit to the mobile unit. Natarajan, col. 4, ll. 39–53; *id.* at col. 7, ll. 59–66, Fig. 6. Each mobile unit transmitter is energized only during the mobile unit's assigned time slot for transmission, whereas the base station transmitter is energized for the entirety of time period A, during which the base station transmits data to the mobile units. *Id.* at col. 4, l. 20–col. 5, l. 29. Dr. Hu admitted these facts in her deposition. Neither Dr. Hu nor the Board, moreover, analyzed whether, if the base station transmitter in Natarajan were modified, its transmissions would be characterized by "*short periods* of intense RF transmission activity on an *otherwise quiet data channel*," as required by the Board's own claim construction. *Apple I*, 2016 WL 3382361, at \*7 (emphasis added).<sup>5</sup> The similarities in transmission hardware

---

<sup>4</sup> Under the *Chenery* doctrine, we decline Apple's invitation to consider evidence that the Board did not cite in its decision. See *Bd. of Trs. of Leland Stanford Junior Univ. v. Chinese Univ. of H.K.*, 860 F.3d 1367, 1376 (Fed. Cir. 2017) (citing *SEC v. Chenery Corp.*, 332 U.S. 194, 196 (1947)) ("We must base our review on the analysis presented by the Board.").

<sup>5</sup> In her dissent, Judge Newman does not discuss the portion of the Board opinion where it explains the

cannot close these gaps without additional, reasoned analysis.

For these reasons, Dr. Hu’s testimony does not constitute substantial evidence that is capable of supporting the Board’s conclusions “that a person of ordinary skill in the art would have been motivated by Natarajan to apply the same power-conserving techniques to base units as it is disclosed with respect to mobile units, as well as that it would have been within the skill of the ordinarily skilled artisan to do so.” *Id.* at \*15. The Board thus relied on

---

rationale for its holding and, instead, relies heavily on the Board’s statement that

“energized in low duty cycle RF bursts” simply means that a transmitter is not energized continuously over the course of network operation, but is depowered during at least two time periods of each communication cycle: first, in time slots in which the unit that includes the transmitter is assigned to receive data; and second, in time slots, if any, when the unit is assigned to transmit data but has no data to transmit.

*Apple I*, 2016 WL 3382361, at \*7. But the dissent reads too much into this sentence. Taken out of context, this passage contradicts the Board’s own explicit claim construction, because it does not incorporate the “short periods” and “otherwise quiet data channel” aspects of that construction. For example, if a transmitter is continuously transmitting data—that is, it is never assigned to receive data and always has data to transmit—the transmitter would satisfy the requirements of the sentence quoted above. But the transmission activity would not be in “short periods,” and the data channel would not be “otherwise quiet.” It follows that the Board’s claim construction requires more than the quoted passage.



“ordinary creativity” “as a wholesale substitute for reasoned analysis and evidentiary support,” and did so “when dealing with a limitation missing from the prior art references specified.” *Arendi*, 832 F.3d at 1362. Without “a reasoned explanation that avoids conclusory generalizations,” this was not sufficient. *Id.* at 1366 (quoting *Perfect Web*, 587 F.3d at 1329).

We also find “that this is not a case where a more reasoned explanation than that provided by the Board can be gleaned from the record.” *Id.* Dr. Hu’s testimony suffers from the serious deficiencies that we have discussed above, and Apple suggests no other evidence that might remedy those defects. Apple failed to meet its burden of establishing that the challenged claims of the ’290 patent were obvious. We therefore reverse the Board’s finding of unpatentability.

### III. CONCLUSION

For the foregoing reasons, we reverse the Board’s findings that claims 1–4 and 9–10 of the ’290 patent are obvious over the combination of Natarajan and Neve.

### **REVERSED**

#### COSTS

No costs.

# United States Court of Appeals for the Federal Circuit

---

DSS TECHNOLOGY MANAGEMENT, INC.,  
*Appellant*

v.

APPLE INC.,  
*Appellee*

---

2016-2523, 2016-2524

---

Appeals from the United States Patent and Trademark Office, Patent Trial and Appeal Board in Nos. IPR2015-00369, IPR2015-00373.

---

NEWMAN, *Circuit Judge*, dissenting.

The court now reverses the PTAB's decision that claims 1–4 and 9–10 of the '290 patent are unpatentable for obviousness, on the court's holding that the PTAB's explanation is inadequate to support its decision.<sup>1</sup> However, if the PTAB's explanation is indeed inadequate, the appropriate appellate action is not to grant final judgment

---

<sup>1</sup> *Apple Inc. v. DSS Tech. Mgmt., Inc.*, No. IPR2015-00369, 2016 WL 3382361 (P.T.A.B. June 17, 2016) (*Apple I*); *Apple Inc. v. DSS Tech. Mgmt., Inc.*, No. IPR2015-00373, 2016 WL 3382464 (P.T.A.B. June 17, 2016) (*Apple II*). The rulings are substantially identical, and I cite only to *Apple I*.

for the opponent. The appropriate action is either (1) to remand for additional explanation, or (2) to decide this question of law. However, the panel majority has neither remanded nor decided the question.

As a further concern, I do not share the view that the PTAB's explanation is deficient. Of course the PTAB must explain its reasoning, and the America Invents Act places significant responsibility on this agency tribunal, in view of the PTO's announced intention to bring its technological expertise to these new proceedings.<sup>2</sup> Thus the PTAB must well and fully explain the evidentiary foundation and legal reasoning for its decision. In the event that the PTAB's findings or reasoning is deemed inadequate for appellate review, the proper appellate response is not to cement this inadequacy into a final judgment for the opposing party.

From the court's errant rulings, I respectfully dissent.

***The PTAB Decision of Unpatentability  
on the Ground of Obviousness is Ade-  
quately Explained***

At the trial the parties agreed that only a single claim clause is at issue; DSS conceded that all other claim limitations are shown in the prior art. Thus the only question before the PTAB was whether it would have been obvious in view of the Natarajan reference that "said

---

<sup>2</sup> See *Patent Reform: The Future of American Innovation: Hearing Before the S. Comm. on the Judiciary*, 110th Cong. 7 (2007), Director Jon W. Dudas:

The idea was that this could serve as a meaningful alternative to litigation, probably less costly, certainly before experts at the Patent and Trade-mark Office.

server and peripheral transmitters be[ ] energized in low duty cycle RF bursts.” ’290 patent, claim 1 (final clause).

The PTAB decision recited the parties’ arguments, described the Natarajan reference and the secondary reference to Neve, and explained why the PTAB agreed with the positions presented by Apple as applied to the claims and the references. *Apple I* at \*8–16. My colleagues’ criticism is that the PTAB repeats the parties’ presentation concerning the ’290 patent and the references, and generally endorses Apple’s arguments concerning obviousness. Maj. Op. at 11–13. Indeed, the PTAB’s opinion states the arguments presented by each side. But the PTAB also states with reasonable clarity how this information contributed to the conclusion of obviousness, with focus on those aspects that controlled the decision.

This form of analysis can be useful, when the presentation of the arguments and surrounding information is adequate to show the foundation and reasoning of the decision. In *Outdry Technologies Corp. v. Geox S.p.A.*, 859 F.3d 1364, 1370 (Fed. Cir. 2017) this court stated: “The Board is permitted to credit a party’s argument as part of its reasoned explanation of its factual findings; it simply must explain why it accepts the prevailing argument.” (quoting *Icon Health & Fitness, Inc. v. Strava, Inc.*, 849 F.3d 1034, 1047 (Fed. Cir. 2017)) (internal quotation marks omitted). In *Paice LLC v. Ford Motor Co.*, 881 F.3d 894 (Fed. Cir. 2018), the court responded to a similar criticism, observing that in rejecting some arguments and accepting others, “the Board’s decisions here cite to the relevant portions of Ford’s briefing that explain how the prior art discloses the relevant claim limitations.” *Id.* at 905. That the PTAB framed its analysis in terms of the parties’ arguments and evidence does not render its decision-making *de facto* inadequate. The concern is not to condone an apparent shortcut in adjudicatory analysis, but to assure that the PTAB “engaged in reasoned decision-making and sufficiently articulated its analysis” to

explain its support in fact and law. *Outdry*, 859 F.3d at 1370.

Here, the PTAB's reasons are sufficiently articulated, as I shall discuss *post*. To be sure, there have been occasions when the PTAB has failed to adequately explain its findings or conclusions, seen in cases collected in *Outdry*, *supra*, where “[m]issing from those Board decisions were citations to the evidence, reasoned explanations, or explicit findings necessary for us to review for substantial evidence.” *Id.* at 1369. Here, however, necessary findings are not missing from the PTAB's decision.

The PTAB recited, and it is not disputed, that “energized in low duty cycle RF bursts” means “energized, in short periods of intense RF transmission activity on an otherwise quiet data channel, only to the extent required to satisfy the data transmission needs over the course of a communication cycle.” *Apple I* at \*7. The PTAB understood that this construction is satisfied when

a transmitter is not energized continuously over the course of network operation, but is depowered during at least two time periods of each communication cycle: first, in time slots in which the unit that includes the transmitter is assigned to receive data; and second, in time slots, if any, when the unit is assigned to transmit data but has no data to transmit.

*Apple I* at \*7.

The PTAB was persuaded by each of Apple's arguments concerning the disputed limitation, and “conclude[d] that it would have been obvious to a person of ordinary skill in the art to energize Natarajan's server transmitter in low duty cycle RF bursts, as recited in claim 1.” *Apple I* at \*15. The PTAB acknowledged, and adopted, Apple's cited evidence and expert's views in its obviousness determination. *See Apple I* at \*16 (“As ex-

plained above, we find, based on Apple's evidence, that the combination of Natarajan and Neve teaches each limitation of claim 1."). Substantial evidence is cited and explained in the PTAB opinion, in support of the PTAB's conclusion.

For example, the PTAB explained in its opinion that Natarajan teaches conserving battery power, stating:

The scheduled access multiaccess protocol is implemented to effectively conserve battery power by suitable control of the state of the controller, the transmitter and receiver units at the wireless link adapter by scheduling when the adapter is in a normal running mode, or a standby mode in which power is conserved.

*Apple I* at \*8 (quoting Natarajan at Abstract; also citing col. 3, l. 66–col. 4, l. 1). The PTAB explained that Natarajan discloses that “[a] desirable solution is one in which the transmitter (or receiver) consumes power only when it is actively transmitting a message (or actively receiving a message).” *Id.* (quoting Natarajan at col. 4, ll. 3–6).

The PTAB found it “uncontested” that Natarajan discloses “peripheral transmitters being energized in low duty cycle RF bursts at intervals determined by a code sequence.” *Apple I* at \*11. DSS does not dispute this explanation, or the extent of uncontested facts.

The PTAB also explained Natarajan's teachings, stating that:

Natarajan discloses that the base station broadcasts a header that includes a list of mobile users that will be receiving data packets from the base station in the current frame, the order in which the mobile users will receive the data packets, and the bandwidth allocated to each user.

*Id.* at \*9 (citing Natarajan at col. 4, ll. 45–53). Accordingly, “a mobile unit that is not included in the header from the base station can turn its receiver ‘OFF’ for the duration of the current subframe.” *Id.* (citing Natarajan at col. 4, ll. 64–67). The PTAB further observed, in explaining its findings, that

the adapter of each receiving mobile unit can compute exactly when it should be ready to receive packets from the base station by adding up the slots allocated to all receiving units that precede it, power ‘ON’ during that time slot to receive its data, and go back to sleep for the remainder of the subframe.

*Id.* (citing Natarajan at col. 4, l. 67–col. 5, l. 6).

With respect to communications from the mobile units to the base station, the PTAB explained that:

Natarajan similarly discloses that the base station broadcasts a header that includes an ordered list of users that will be allowed to transmit packets to the base station in the current frame and the bandwidth allocated to each.

*Id.* (citing Natarajan at col. 5, ll. 9–19). The PTAB found that each mobile unit can use the information broadcast in the header to compute exactly when the mobile unit should transmit to the base station, shutting down both the transmitter and receiver of the mobile units when not in use. *Id.* (citing Natarajan at col. 5, ll. 23–29).

The PTAB’s written decision also recited the DSS argument that Natarajan’s base unit’s transmitter “encapsulate data and control information in an HDLC (high-level data link control) packet structure and provide the packet in serial form to the RF transceiver 54;” DSS stated that “HDLC involves continuous transmissions in which special bit sequences—i.e. idle words—are trans-

mitted when no data transmission is required.” *Apple I* at \*12 (quoting DSS Patent Owner Response at 20–21).

The PTAB summarized the DSS arguments that “[t]he HDLC packet structure disclosed in Natarajan is inconsistent with a server transmitter being energized in low duty cycle RF bursts” and “[i]t is well-known in the art that HDLC is an example of a bit-oriented framing that involves a continuous outbound transmission rather than operation in low duty cycle RF bursts.” *Apple I* at \*12 (quoting DSS Patent Owner Response at 20). However, the PTAB found that Apple persuasively refuted these arguments, referring to Apple’s explanation that Natarajan’s HDLC protocol was actually consistent with low duty cycle RF bursts, and pointed out that the preferred embodiment of the ’290 patent utilized the HDLC protocol. *Apple I* at \*13–14.

Apple also explained that a reference cited by Natarajan in discussing the HDLC protocol, Mischa Schwartz, *Telecommunication Networks: Protocols, Modeling and Analysis*, Addison–Wesley (1988) (“Schwartz”) supports the conclusion that Natarajan’s HDLC protocol is consistent with both low duty cycle communication and RF transmissions occurring in bursts. *Apple I* at \*14.

The PTAB referred to Schwartz’s explanation that “[w]hen the transmitter reaches its maximum sequence number it is forced to stop transmitting until a frame in the reverse direction is received, acknowledging an outstanding packet.” *Apple I* at \*14. The PTAB also referred to Apple’s citation of Figure 4-13, which showed the HDLC protocol having the transmitter idle between frames. *Id.*

The PTAB discussed this evidence in the bigger picture of applying a low duty cycle to Natarajan’s base unit’s transmitter. “Apple argue[d] that a person of ordinary skill in the art would have understood from Natarajan that, when Natarajan’s base station is not



transmitting, its transmitter is powered off.” *Apple I* at \*13. This point was uncontested, for DSS conceded that Natarajan’s base unit transmitter would be powered down when not transmitting. J.A.409 (Patent Owner Response at 22 n.3) (“Patent Owner acknowledges that the operation of the base transmitter is not continuous over the entire frame because the base transmitter is powered down during inbound traffic in Period B.”). Hence, the parties (and the PTAB) focused on the power and transmission status of Natarajan’s base unit transmitter during Period A.

The PTAB’s finding that it would have been obvious for “said server and peripheral transmitters being energized in low duty cycle RF bursts” was buttressed by Natarajan’s explanation that “[m]ost users are very likely to be inactive (both Transmit-Inactive and Receive-Inactive) most of the time for most applications. This is primarily due to the bursty nature of data communication traffic.” Natarajan at col. 6, ll. 41–44. The PTAB cited this passage in its discussion of Apple’s argument that “a person of ordinary skill in the art would have understood from Natarajan that, when Natarajan’s base station is not transmitting, its transmitter is powered off.” *Apple I* at \*13.

The PTAB also cited the declaration of Apple’s expert, Dr. Hu, which discussed this passage and relied upon it to opine that “the base station will not have information to transmit most of the time,” and concluded that this met the “low duty cycle RF bursts” limitation because “when it is not transmitting, it will be powered off.” *Id.* (citing J.A.1994 (Declaration of Dr. Hu)).<sup>3</sup> Likewise, the PTAB

---

<sup>3</sup> The panel majority characterizes Dr. Hu’s testimony, and the PTAB’s citation to ¶¶ 44–45 of Dr. Hu’s declaration, as “conclusory” and “unspecific.” Maj. Op. at 14. However, in the context of the PTAB’s construction of

cited the cross-examination of Apple's expert, Dr. Grimes, who explained that during Natarajan's Period A, the base unit transmitter "only transmits during those periods when there's a receiver that's allocated to receive the information" and that "the transmitter is off when it's not transmitting." *Id.* (citing Deposition of Dr. Grimes at 68:5–7, 75:21–22).

The panel majority does not discuss or review the evidence cited by the PTAB in its decision. This evidence well supports the PTAB's conclusion that "Natarajan's disclosure of the HDLC protocol is consistent with Natarajan's base units being energized in low duty cycle RF bursts, as that term is properly construed." *Apple I* at \*15. To teach the limitation at issue, Natarajan need only have taught a base unit wherein the "transmitter is not energized continuously over the course of network operation, but is depowered during at least two time periods of each communication cycle: first, in time slots in which the unit that includes the transmitter is assigned to receive data; and second, in time slots, if any, when the unit is assigned to transmit data but has no data to transmit." *See Apple I* at \*7.<sup>4</sup>

---

the disputed limitation, *Apple I* at \*7, the testimony is directly on the point for which it was cited.

<sup>4</sup> The panel majority argues that I read too much into this sentence, and that if "[t]aken out of context, this passage contradicts the Board's own explicit claim construction." Maj. Op. at 15 n.5. I agree that we should read statements in PTAB decisions in their proper context, including statements concerning the parties' arguments, cited evidence, and what was found to be persuasive. I also agree that we should interpret the PTAB's statements correctly. The majority's example, in its n.5, illustrates this point. A hypothetical transmitter that continuously transmits data and is never assigned to

DSS conceded at the PTAB that during Period B, Natarajan’s base unit transmitter would be powered down. DSS has maintained this position on appeal. DSS Br. at 25 (“[D]uring Period B, the base unit transmitter is not energized at all—in bursts or otherwise—at any time outside of Header BH.”). This meets the first time period for depowering referred to in the PTAB’s construction.

Natarajan’s teachings about the “Receive-Inactive” status of most mobile units most of the time during Period A, particularly as explained by Apple’s expert witnesses, meets the second time period for depowering referred to in the PTAB’s construction. Accepting that the technology is complex, as my colleagues state, this court held in *Ariosa Diagnostics v. Verinata Health, Inc.*, 805 F.3d 1359, 1365 (Fed. Cir. 2015), that “[w]e may affirm an agency ruling if we may reasonably discern that it followed a proper path, even if that path is less than perfectly clear.” The PTAB

---

receive data could not satisfy the minimum two time period depowering requirement explicitly referred to in the PTAB’s explanation of the meaning of “energized in low duty cycle RF bursts” and quoted by the majority. First, such a transmitter could not be depowered “in time slots in which the unit that includes the transmitter is assigned to receive data,” per the PTAB’s explanation, for no such time slots exist as the majority’s transmitter “is never assigned to receive data.” Second, such a transmitter could not be depowered “in time slots, if any, when the unit is assigned to transmit data but has no data to transmit,” per the PTAB’s explanation, for the majority’s transmitter “is continuously transmitting data” and “always has data to transmit.” The majority reaches the wrong conclusion from its hypothetical, for its transmitter is not “depowered during at least two time periods of each communication cycle,” as the PTAB’s explanation requires.

followed an appropriate, discernable pathway to reach its conclusion that the challenged claims would have been obvious. Again, the panel majority does not discuss or critically consider the evidence cited by the PTAB in its decision.

The principle established in *Chenery* requires that “the orderly functioning of the process of review requires that the grounds upon which the administrative agency acted be clearly disclosed and adequately sustained.” *SEC v. Chenery Corp.*, 318 U.S. 80, 94 (1943); *see also Timken U.S. Corp. v. United States*, 421 F.3d 1350, 1355 (Fed. Cir. 2005) (“[A]n agency must explain its action with sufficient clarity to permit ‘effective judicial review.’”); *Mullins v. U.S. Dep’t of Energy*, 50 F.3d 990, 992 (Fed. Cir. 1995) (“[A]gencies have a duty to provide reviewing courts with a sufficient explanation for their decisions so that those decisions may be judged against the relevant statutory standards . . .”).

The PTAB in its decision explained the meaning of the disputed limitation in the context of the teachings of Natarajan, and presented an analysis with the evidence that supported its conclusion. The requirements of *Chenery* were met. In stating that this court “cannot” itself decide the question of obviousness based on Natarajan, my colleagues state that “a more reasoned explanation than that provided by the PTAB can[not] be gleaned from the record.” That statement is not in accord with the PTAB’s decision, for the record is heavy with testimony, briefing, and argument, presented by the Petitioner Apple and the Patent Owner DSS, and the PTAB’s decision cites and explains the resources on which it reached its conclusion, presenting the arguments and evidence on both sides, and explaining its conclusion. The factual findings that underlie that conclusion are supported by substantial evidence, and the PTAB’s decision of obviousness is fully supported, and should be sustained.

***Reversal is not a Remedy for Inadequate Explanation***

If the PTAB's analysis were indeed deficient, "the proper course, except in rare circumstances, is to remand to the agency for additional investigation or explanation." *Fla. Power & Light Co. v. Lorion*, 470 U.S. 729, 744 (1985). "[W]hen the [PTAB]'s action is potentially lawful but insufficiently or inappropriately explained, we have consistently vacated and remanded for further proceedings." *In re Van Os*, 844 F.3d 1359, 1362 (Fed. Cir. 2017) (internal quotation marks omitted) (collecting cases). Deficient adjudication is not grounds for a decision on the merits. On the majority's theory that the PTAB's explanation was inadequate, the appropriate remedy is to return the matter to the PTAB for better explanation, on any of the reasons compiled in *Outdry*. The court errs in simply reversing the PTAB's decision.

My colleagues also criticize the PTAB's understanding of the prior art, stating that "the Board failed to consider that Natarajan's multi-access protocol imposes different transmission requirements on the base station and the mobile units." Maj. Op. at 15. However, the majority limits its examination of Natarajan to only a portion of its disclosure—Period A. *Id.* Neither Apple nor the PTAB restricted Natarajan's disclosure to this Period. *See, e.g.*, PTAB Op. at \*11 (citing Natarajan's discussions of Period B).

By ignoring Period B, as well as the base unit transmission of header BH, the majority overlooks the segment of Natarajan's cycle in which the base unit transmitter transmits, goes quiet and, as DSS admitted both before the PTAB and on appeal, would be powered down. J.A.409 (Patent Owner Response at 22 n.3); DSS Br. at 25 ("[D]uring Period B, the base unit transmitter is not energized at all—in bursts or otherwise—at any time outside of Header BH.").

Moreover, the transmission requirements of the mobile units and the base units are intertwined, for the mobile units and the base unit are in direct communication with each other through transmission and reception in Natarajan's scheduled multi-access protocol. *See, e.g.*, J.A.2331–32 (Deposition of Dr. Grimes). Natarajan explains that “[m]ost users are very likely to be inactive (both Transmit-Inactive and Receive-Inactive) most of the time for most applications. This is primarily due to the bursty nature of data communication traffic.” Natarajan at col. 6, ll. 41–44. Accordingly, “Receive-Inactive” mobile units suggest a “Transmit-Inactive” base unit. *See, e.g.*, J.A.1993–95 (Declaration of Dr. Hu).

The majority faults the PTAB for failing to discuss “whether, if the base station transmitter in Natarajan were modified, its transmissions would be characterized by ‘*short periods of intense RF transmission activity on an otherwise quiet data channel*,’ as required by the Board’s own claim construction.” Maj. Op. at 15. However, the evidence is that this is the natural result of Natarajan’s communication protocol. Apple’s expert witnesses sufficiently explained that if Natarajan’s mobile units are likely to be “Receive-Inactive” most of the time, Natarajan’s base unit transmitter would operate by transmitting during header AH, followed by very little or no transmission during Period A, then transmission during header BH, followed by no transmission during Period B. *See* J.A.1993–95, 2013–15 (Declaration of Dr. Hu); J.A.2331–32 (Deposition of Dr. Grimes); *Apple I*, Exhibit 1008 at ¶¶ 115, 116 (Declaration of Dr. Grimes).

This explanation and evidence meet the claim limitation that is in dispute. *See Apple I* at \*7 (“[E]nergized in low duty cycle RF bursts’ simply means that a transmitter is not energized continuously over the course of network operation, but is depowered during at least two time periods of each communication cycle: first, in time slots in which the unit that includes the transmitter is assigned

to receive data; and second, in time slots, if any, when the unit is assigned to transmit data but has no data to transmit.”).

My colleagues do not mention this analysis, which also meets the alternative formulation of the claim limitation, namely “energized, in short periods of intense RF transmission activity on an otherwise quiet data channel, only to the extent required to satisfy the data transmission needs over the course of a communication cycle.” *Id.* Natarajan’s base unit would be “Transmit-Inactive” most of the time, for the transmission of headers AH and BH are taught to “represent a small fraction of the whole frame length.” Natarajan at col. 6, ll. 39–47. With no need to send transmissions to mobile units, the base unit transmitter would be powered down to reduce power consumption when not transmitting, in accordance with the unchallenged motivation that the PTAB expressly found. The PTAB explained in *Apple I* at \*15:

We are persuaded that a person of ordinary skill in the art would have been motivated by Natarajan to apply the same power-conserving techniques to base units as it is disclosed with respect to mobile units . . . .

Apple’s experts provided a sufficient predicate for the PTAB to find that this would afford short periods of intense RF transmissions by Natarajan’s base unit transmitter on an otherwise quiet data channel. *Compare* Declaration of Dr. Hu at ¶¶ 42–45 (J.A.1992–95) with ¶¶ 85–88 (J.A.2015–17); *Apple I*, Exhibit 1008 at ¶¶ 115, 116 (Declaration of Dr. Grimes).

The PTAB explained its decision in accordance with the evidence and the prior art, as presented by the parties and as analyzed by the PTAB, to support the conclusion that Natarajan’s base unit’s transmitter would have operated, or it would have been obvious to operate, by “short periods of intense RF transmission activity on an

otherwise quiet data channel,” the construed words of the claim.

The appellate role, on review of the agency decision, includes “determin[ing] whether it is arbitrary or capricious, or, if bound up with a record-based factual conclusion, to determine whether it is supported by substantial evidence.” *Dickinson v. Zurko*, 527 U.S. 150, 164 (1999) (internal quotation marks omitted). If the agency’s presentation is inadequate to demonstrate its reasoning, the appropriate remedy is not to issue a final judgment on appeal. *See Rovalma, S.A. v. Bohler-Edelstahl GmbH & Co. KG*, 856 F.3d 1019, 1026 (Fed. Cir. 2017) (“The Board has not provided a sufficiently focused identification of the relevant evidence or explanation of its inferences for us to confidently review its decision and avoid usurping its fact-finding authority. Accordingly, as we have concluded in similar circumstances, these deficiencies call for a vacatur and remand for further explanation from the Board.”) (citation omitted) (collecting cases); *see also Van Os*, 844 F.3d at 1362; *Personal Web Techs., LLC v. Apple, Inc.*, 848 F.3d 987, 994 (Fed. Cir. 2017); *In re NuVasive, Inc.*, 842 F.3d 1376, 1385 (Fed. Cir. 2016); *Power Integrations, Inc. v. Lee*, 797 F.3d 1318, 1325 (Fed. Cir. 2015); *In re Sang-Su Lee*, 277 F.3d 1338, 1346 (Fed. Cir. 2002).

The Court has so held, *see F.T.C. v. Sperry & Hutchinson Co.*, 405 U.S. 233, 250 (1972) (“[T]he preferable course would have been to remand the case to the Commission for further proceedings.”); *Fed. Power Comm’n v. United Gas Pipe Line Co.*, 393 U.S. 71, 73 (1968); *SEC v. Chenery Corp.*, 318 U.S. 80, 95 (1943).

My colleagues’ action in simply reversing the ruling of the PTAB, producing a final judgment of patentability that is purportedly subject to estoppel in any district court proceeding between these parties, is contrary to the body of precedent, and dilutes the purpose of these post-grant proceedings. I respectfully dissent from this ruling.