

**United States Court of Appeals
for the Federal Circuit**

**TECHNOLOGY PROPERTIES LIMITED LLC,
PHOENIX DIGITAL SOLUTIONS LLC, PATRIOT
SCIENTIFIC CORPORATION,
*Plaintiffs-Appellants***

v.

**HUAWEI TECHNOLOGIES CO., LTD., FUTUREWEI
TECHNOLOGIES, INC., HUAWEI DEVICE CO.,
LTD., HUAWEI DEVICE USA INC., HUAWEI
TECHNOLOGIES USA INC., ZTE CORPORATION,
ZTE USA, INC., SAMSUNG ELECTRONIC CO., LTD,
SAMSUNG ELECTRONICS AMERICA, INC., LG
ELECTRONICS, INC., LG ELECTRONICS U.S.A.,
INC., NINTENDO CO., LTD, NINTENDO OF
AMERICA, INC.,
*Defendants-Appellees***

2016-1306, 2016-1307, 2016-1309, 2016-1310, 2016-1311

Appeals from the United States District Court for the
Northern District of California in Nos. 3:12-cv-03865-VC,
3:12-cv-03876-VC, 3:12-cv-03877-VC, 3:12-cv-03880-VC,
3:12-cv-03881-VC, Judge Vince Chhabria.

Decided: March 3, 2017

THOMAS CECIL, Nelson Bumgardner PC, Fort Worth, TX, argued for all plaintiffs-appellants. Plaintiff-appellant Phoenix Digital Solutions LLC also represented by BARRY JAMES BUMGARDNER, BRENT N. BUMGARDNER, EDWARD R. NELSON, III; TRAVIS CAMPBELL, ROBERT GREENSPOON, Flachsbart & Greenspoon, LLC, Chicago, IL.

BARRY JAMES BUMGARDNER, Nelson Bumgardner PC, Fort Worth, TX, for plaintiff-appellant Technology Proper-tied Limited, LLC. Also represented by WILLIAM L. BRETSCHNEIDER, Silicon Valley Law Group, San Jose, CA.

CHARLES THOMAS HOGE, Kirby Noonan Lance & Hoge LLP, San Diego, CA, for plaintiff-appellant Patriotic Scientific Corporation.

MARK D. FOWLER, DLA Piper US LLP, East Palo Alto, CA, argued for all defendants-appellees. Defendants-appellees Samsung Electronic Co., Ltd., Samsung Elec-tronics America, Inc. also represented by ERIK RYAN FUEHRER, AARON WAINSCOT; JAMES MARTIN HEINTZ, Reston, VA; STANLEY JOSEPH PANIKOWSKI, III, ROBERT CHEN WILLIAMS, San Diego, CA.

TIMOTHY C. BICKHAM, Steptoe & Johnson, LLP, Wash-ington, DC, for defendants-appellees Huawei Technologies Co., Ltd., Futurewei Technologies, Inc., Huawei Device Co., Ltd., Huawei Device USA Inc., Huawei Technologies USA Inc.

CHARLES M. MCMAHON, McDermott, Will & Emery LLP, Chicago, IL, for defendants-appellees ZTE Corpora-tion, ZTE USA, Inc. Also represented by HERSH H. MEHTA.

CHRISTIAN A. CHU, Fish & Richardson, PC, Washing-ton, DC, for defendants-appellees LG Electronics, Inc., LG

Electronics U.S.A., Inc. Also represented by SCOTT ANDREW ELENGOLD.

STEPHEN R. SMITH, Cooley LLP, Washington, DC, for defendants-appellees Nintendo Co., Ltd., Nintendo of America, Inc. Also represented by MATTHEW J. BRIGHAM, Palo Alto, CA.

Before MOORE, WALLACH, and CHEN, *Circuit Judges*.

MOORE, *Circuit Judge*.

The present appeals arise from five cases in the Northern District of California. Technology Properties Limited LLC, Phoenix Digital Solutions LLC, and Patriot Scientific Corp. (collectively “Technology Properties”) asserted U.S. Patent No. 5,809,336 (the “336 patent”) against Huawei Technologies Co., Ltd., Futurewei Technologies, Inc., Huawei Device Co., Ltd., Huawei Device USA Inc., Huawei Technologies USA Inc., ZTE Corp., ZTE USA, Inc., Samsung Electronics Co., Ltd., Samsung Electronics America, Inc., LG Electronics, Inc., LG Electronics U.S.A., Inc., Nintendo Co., Ltd., and Nintendo of America Inc. (collectively “Appellees”) in five separate litigations. After claim construction, the parties stipulated to non-infringement based on the district court’s construction of “an entire oscillator disposed upon said integrated circuit substrate.” Technology Properties appealed, and our court consolidated the appeals. Because the district court erred in a portion of its construction of “entire oscillator,” we vacate and remand.

I. BACKGROUND

A. The ’336 Patent

The ’336 patent discloses a microprocessor with two independent clocks—a variable frequency system clock connected to the central processing unit (“CPU”) and a

fixed-frequency clock connected to the input/output (“I/O”) interface. ’336 patent at 3:26–35. The variable-frequency system clock is a ring oscillator. *Id.* at 16:56–57. A ring oscillator is made by connecting an odd number of inverters in series, then connecting the output of the final inverter to the input of the first, creating an inherently unstable (i.e., oscillating) output. *Id.* at Fig. 18. A ring oscillator’s frequency is considered “variable” because it fluctuates based on external stressors such as temperature and voltage. *Id.* at 16:59–67. For example, the same circuit will oscillate at 100 MHz at room temperature but only 50 MHz at 70 degrees Celsius. *Id.*

The ’336 patent’s I/O clock is a quartz crystal. *Id.* at 17:25–27. A crystal is a piece of material that oscillates at a specific frequency when voltage is applied. Unlike ring oscillators, crystals maintain a steady frequency regardless of their environment. For this reason, the I/O clock in the ’336 patent is considered “fixed.” *See id.* at 17:33 (describing the “fixed speed” I/O interface).

The ’336 patent teaches improving microprocessor performance by decoupling the CPU and I/O clocks. The variable-speed CPU clock is fabricated on the same silicon substrate as the rest of the microprocessor, including the CPU itself. *Id.* at 16:57–58. Because the CPU and CPU clock are fabricated on the same silicon substrate, they react similarly to external stressors. *Id.* at 16:63–67. This allows the maximum processing speed of the CPU to track the oscillating frequency of its clock. As the patent describes it, the “CPU 70 will always execute at the maximum frequency possible, but never too fast.” *Id.* at 17:1–2. The I/O clock is located off-chip and controls the chip’s I/O interface. “By decoupling the variable speed of the CPU 70 from the fixed speed of the I/O interface 432, optimum performance can be achieved by each.” *Id.* at 17:32–34. The two-clock arrangement is illustrated in Figure 17:

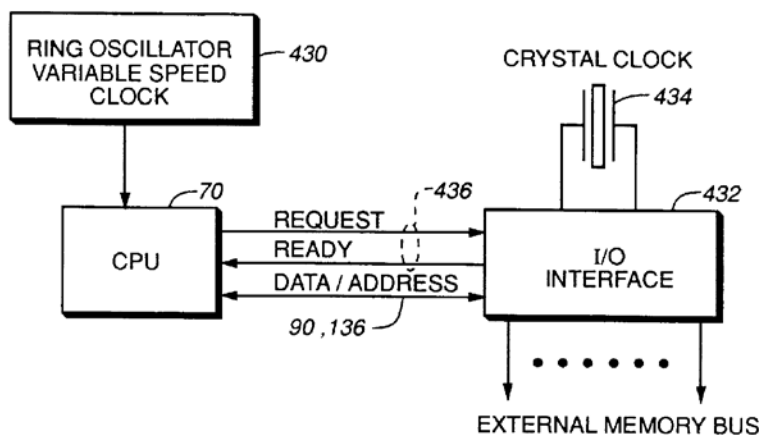
**FIG. 17**

Id. at Fig. 17.

Claim 6 of the '336 patent is representative:

A microprocessor system comprising:

a central processing unit disposed upon an integrated circuit substrate, said central processing unit operating at a processing frequency and being constructed of a first plurality of electronic devices;

an entire oscillator disposed upon said integrated circuit substrate and connected to said central processing unit, said oscillator clocking said central processing unit at a clock rate and being constructed of a second plurality of electronic devices, thus varying the processing frequency of said first plurality of electronic devices and the clock rate of said second plurality of electronic devices in the same way as a function of parameter variation in one or more fabrication or operational parameters associated with said integrated circuit substrate, thereby enabling said processing frequency to

track said clock rate in response to said parameter variation;

an on-chip input/output interface, connected between said central processing unit and an external memory bus, for facilitating exchanging coupling control signals, addresses and data with said central processing unit; and

an external clock, independent of said oscillator, connected to said input/output interface wherein said external clock is operative at a frequency independent of a clock frequency of said oscillator.

'336 patent, claim 6 (emphasis added). Claim 6 requires, among other things, “an entire oscillator disposed upon said integrated circuit substrate,” which refers to the variable-frequency CPU clock. The district court construed the term to mean “an oscillator located entirely on the same semiconductor substrate as the central processing unit *that does not require a control signal and whose frequency is not fixed by any external crystal.*” J.A. 7 (emphasis added).¹ The parties agree to the first half of the construction but dispute the emphasized portion. J.A. 13.

Appellees contend the second half of the construction is proper because the patentee disclaimed certain claim scope during prosecution to overcome rejections based on U.S. Patent Nos. 4,503,500 (“Magar”) and 4,670,837 (“Sheets”). Specifically, Appellees contend the construction “whose frequency is not fixed by any external crystal” is mandated by the patentee’s disclaiming statements relating to Magar, and the construction “that does not

¹ References to the district court’s opinion refer to the Magistrate Judge’s Claim Construction Report and Recommendation, which the District Judge reviewed de novo and adopted without modification. See J.A. 5.

require a control signal” is required by disclaiming statements relating to Sheets. Each reference is discussed in turn below.

B. The Magar Reference

Magar is a 1985 patent assigned to Texas Instruments that discloses a basic microprocessor. The Magar chip contains a clock generator (CLOCK GEN) located on the same silicon substrate as the remainder of the processor. The inputs of CLOCK GEN are pins X1 and X2, which are connected to a crystal or some other external generator. CLOCK GEN uses the signal from the external crystal to generate four clocks, Q1–Q4, that drive the chip. CLOCK GEN also regulates the chip’s timing or synchronization with external components with the CLKOUT pin. This is illustrated in Figure 2a:

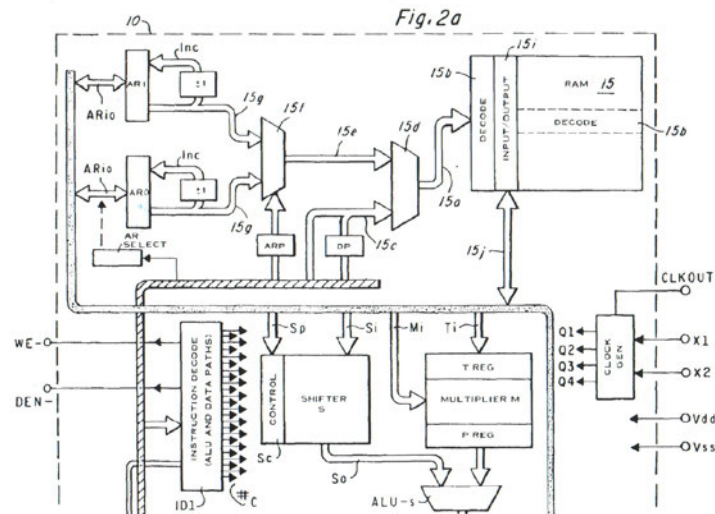

J.A. 2044.

During prosecution, the examiner rejected what would become claim 6 of the '336 patent under 35 U.S.C. § 103 in light of Magar. The patentee responded that

Magar did not disclose the “entire oscillator” limitation and sought to traverse the rejection. In doing so, it made several statements the district court found to be disclaiming. First, the district court found that the patentee “attempted to distinguish Magar by emphasizing that the clock disclosed in Magar was fixed by a crystal that was external to the microprocessor, unlike their on-chip variable speed clock.” J.A. 9 (citing the following statement from the prosecution history).

[O]ne of ordinary skill in the art should readily recognize that the speed of the cpu [sic] and the clock *do not* vary together due to manufacturing variation, operating voltage and temperature of the [integrated circuit] in the Magar microprocessor, as taught in the above quotation from the reference. This is simply because the Magar microprocessor clock is frequency controlled by a crystal which is also external to the microprocessor. Crystals are by design fixed-frequency devices whose oscillation speed is designed to be tightly controlled and to vary minimally due to variations in manufacturing, operating voltage and temperature. The Magar microprocessor in no way contemplates a variable speed clock as claimed.

J.A. 2092–93. Next, the district court stated that “the applicants also argued that the Magar clock could not practice the claimed invention because of its reliance on a crystal, which by its nature cannot vary its oscillator frequency.” J.A. 9 (citing the following statement from the prosecution history).

[C]rystal oscillators have never, to Applicant’s knowledge, been fabricated on a single silicon substrate with a CPU, for instance. Even if they were, as previously mentioned, crystals are by design fixed-frequency devices whose oscillation frequency is designed to be tightly controlled and to

vary minimally due to variations in manufacturing, operating voltage and temperature. The oscillation frequency of a crystal on the same substrate with the microprocessor would inherently not vary due to variations in manufacturing, operating voltage and temperature in the same way as the frequency capability of the microprocessor on the same underlying substrate, as claimed.

J.A. 2093. Third, the district court held that “[t]he applicants also disclaimed the use of an external crystal to cause clock signal oscillation.” J.A. 10 (citing the following statement from the prosecution history).

Magar’s clock generator relies on an external crystal connected to terminals X1 and X2 to oscillate, as is conventional in microprocessor designs. It is not an entire oscillator in itself. And with the crystal, the clock rate generated is also conventional in that it is at a fixed, not a variable, frequency. The Magar clock is comparable in operation to the conventional crystal clock 434 depicted in Fig. 17 of the present application for controlling the I/O interface at a fixed rate frequency, and not at all like the clock on which the claims are based, as has been previously stated.

J.A. 2101. Based on these statements, the district court concluded that “the applicants surrendered any oscillator that like Magar’s is fixed by an off-chip crystal” and held that the construction of “entire oscillator” must include the limitation “whose frequency is not fixed by any external crystal.” J.A. 7, 15.

C. The Sheets Reference

Sheets is a patent assigned to AT&T/Bell Labs that discloses a microprocessor with a variable-frequency clock. The Sheets CPU conserves power by occasionally

operating below its maximum frequency. The clock's frequency correlates to the processing demands faced by the CPU. When the CPU faces a heavier processing load, its clock runs at a higher frequency. When the CPU faces a lighter load, its clock runs at a lower frequency.

Sheets teaches a CPU timed by a voltage-controlled oscillator ("VCO"), which transmits the clock signal to the CPU. The CPU constantly measures its current processing load and computes an appropriate operating frequency. It communicates this information to the VCO, which throttles its frequency accordingly.

The examiner initially rejected claim 6 of the '336 patent under § 103 in light of Sheets. Like the Magar reference, the patentee traversed the rejection by arguing Sheets failed to disclose an "entire oscillator," along the way making several statements the district court found constituted disclaimers. First, the district court noted that "the applicants distinguished their 'present invention' from microprocessors that rely on frequency control information from an external source." J.A. 10 (citing the following statement from the prosecution history).

The present invention does not similarly rely upon provision of frequency control information to an external clock, but instead contemplates providing a ring oscillator clock and the microprocessor within the same integrated circuit. The placement of these elements within the same integrated circuit obviates the need for provision of the type of frequency control information described by Sheets, since the microprocessor and clock will naturally tend to vary commensurately in speed as a function of various parameters (e.g., temperature) affecting circuit performance. Sheets' system for providing clock control signals to an external clock is thus seen to be unrelated to the

integral microprocessor/clock system of the present invention.

J.A. 2117. Second, addressing statements made in response to a later office action, the district court found that “the applicants went even further and disclaimed the use of controlled inputs altogether, regardless whether the control is on-chip or not.” J.A. 11 (citing the following statement from the prosecution history).

Even if the Examiner is correct that the variable clock in Sheets is in the same integrated circuit as the microprocessor of system 100, that still does not give [sic] the claimed subject matter. In Sheets, a command input is required to change the clock speed. In the present invention, the clock speed varies correspondingly to variations in operating parameters of the electronic devices of the microprocessor because both the variable speed clock and the microprocessor are fabricated together in the same integrated circuit. No command input is necessary to change the clock frequency.

J.A. 2127. Third, the district court found that “the applicants left no doubt that, unlike ‘all cited references,’ the claimed oscillator is completely free of inputs and extra components.” J.A. 11 (citing the following statement from the prosecution history).

Crucial to the present invention is that since both the oscillator or variable speed clock and driven device are on the same substrate, when the fabrication and environmental parameters vary, the oscillation or clock frequency and the frequency capability of the driven device will automatically vary together. This differs from all cited references in that the oscillator or variable speed clock and the driven device are on the same substrate, and that the oscillator or variable speed clock var-

ies in frequency but does not require manual or programmed inputs or external or extra components to do so.

J.A. 2094. The district court found that based on these statements, “[t]he applicants distinguished Sheets repeatedly on the ground that Sheets requires control signals, frequency control information or command inputs.” J.A. 16. It then held that the construction of “entire oscillator” must include the limitation “that does not require a control signal.” J.A. 7.

Technology Properties appeals the district court’s construction. We have jurisdiction pursuant to 28 U.S.C. § 1295(a)(1).

II. DISCUSSION

An applicant’s statements to the PTO characterizing its invention may give rise to prosecution disclaimer. *Uship Intellectual Props., LLC v. United States*, 714 F.3d 1311, 1315 (Fed. Cir. 2013). Prosecution disclaimer can arise from both claim amendments and arguments made to the PTO. *Biogen Idec, Inc. v. GlaxoSmithKline LLC*, 713 F.3d 1090, 1095 (Fed. Cir. 2013). The doctrine does not apply unless the disclaimer is “both clear and unmistakable to one of ordinary skill in the art.” *Elbex Video, Ltd. v. Sensormatic Elecs. Corp.*, 508 F.3d 1366, 1371 (Fed. Cir. 2007) (quotations omitted). When determining whether disclaimer applies, we consider the statements in the context of the entire prosecution. *MIT v. Shire Pharm., Inc.*, 839 F.3d 1111, 1119 (Fed. Cir. 2016). If the challenged statements are ambiguous or amenable to multiple reasonable interpretations, prosecution disclaimer is not established. *Id.*

We review claim construction de novo except for subsidiary fact findings, which we review for clear error. *Teva Pharm. USA, Inc. v. Sandoz, Inc.*, 135 S. Ct. 831, 841–42 (2015).

A. Disclaimer Based on Magar

Technology Properties argues the district court erred by limiting an “entire oscillator” to one “whose frequency is not fixed by any external crystal.” It distinguishes Magar by arguing that Magar requires an off-chip crystal oscillator, while claim 6 of the ’336 patent generates the CPU clock signal on-chip. It argues Magar’s only oscillator is the off-chip crystal that is input to CLOCK GEN, which is located on the same silicon substrate as the CPU. It argues CLOCK GEN itself is not an oscillator because it simply takes the output of the off-chip crystal and modifies it to produce four derivative signals. For these reasons, it argues Magar is distinguishable from the claimed invention because Magar’s clock signal is generated off-chip, while the ’336 patent claims generate a clock signal on-chip. It contends the district court misinterpreted this argument in the prosecution history. *See* Appellants’ Br. 34–43.

The argument Technology Properties raises on appeal may have been sufficient to traverse the Magar rejection and avoid a narrower construction, but this is not the same argument the patentee presented during prosecution. Throughout the prosecution history, the patentee argued Magar was distinguishable for two specific reasons: (1) it discloses a fixed-frequency crystal rather than a variable-frequency ring oscillator, and (2) it requires an external (off-chip) generator. The patentee made these distinctions in the first paragraph of its first office action response addressing Magar, arguing Magar was distinguishable because “the clock disclosed in the Magar reference is in fact driven by a fixed frequency crystal, which is external to the Magar integrated circuit.” J.A. 2091. And the patentee included these distinctions in its concluding paragraph to a later office action response, summarizing that Magar was “specifically distinguished from the instant case in that it is both fixed-frequency (being crystal based) *and* requires an external crystal or

external frequency generator.” J.A. 2103 (emphasis added). The district court’s construction properly includes both of the patentee’s clear disclaimers.

The first aspect of the patentee’s disclaimer is that the “entire oscillator” cannot be a fixed-frequency crystal oscillator. The patentee argued to the examiner, “it is clear that the element in Fig. 17 [of the ’336 patent] missing from Fig. 2a in Magar is the ring counter variable speed clock 430.” J.A. 2092. It explained that “[t]he Magar microprocessor in no way contemplates a variable speed clock as claimed.” J.A. 2093. It then distinguished Magar on the grounds that its crystal clock rate “is at a fixed, not a variable, frequency.” J.A. 2101. We agree with the district court’s conclusion that based on these statements, the “entire oscillator” must be a variable frequency oscillator rather than a fixed-frequency crystal. See J.A. 9–10. The patentee’s disclaimer may not have been necessary, but its statements made to overcome Magar were clear and unmistakable.

The second aspect of the patentee’s disclaimer is that the “entire oscillator” cannot require an external crystal or frequency generator. During prosecution, the patentee characterized Magar as teaching a “frequency controlled by a crystal which is also external to the microprocessor.” J.A. 2092–93. It argued Magar was distinguishable because “Magar’s clock generator relies on an external crystal . . . to oscillate.” J.A. 2101. Unlike the claimed “entire oscillator,” the patentee stated that Magar’s on-chip clock generator in isolation “lacks the crystal or external generator” necessary to run the on-chip clock generator. J.A. 2102. And it explained that the ’336 patent’s entire oscillator was novel because “it oscillates without external components (unlike the Magar reference).” J.A. 2102. We hold that the district court’s narrowing construction based on Magar—“whose frequency is not fixed by any external crystal”—properly encapsulates the patentee’s disclaiming statements.

Technology Properties presented clear and concise arguments about the distinctions between Magar and the '336 patent in its briefing to our court. Had those same arguments been made to the Patent Office, our construction may have been different because the patentee likely disclaimed more than was necessary to overcome the examiner's rejection. But the scope of surrender is not limited to what is absolutely necessary to avoid a prior art reference; patentees may surrender more than necessary. *See Norian Corp. v. Stryker Corp.*, 432 F.3d 1356, 1361–62 (Fed. Cir. 2005); *Fantasy Sports Props., Inc. v. Sportline.com, Inc.*, 287 F.3d 1108, 1114–15 (Fed. Cir. 2002). When this happens, we hold patentees to the actual arguments made, not the arguments that could have been made. *Norian*, 432 F.3d at 1361–62. The question is what a person of ordinary skill would understand the patentee to have disclaimed during prosecution, not what a person of ordinary skill would think the patentee needed to disclaim during prosecution.

We affirm the district court's construction that an “entire oscillator” is one “whose frequency is not fixed by any external crystal.”

B. Disclaimer Based on Sheets

Technology Properties argues the district court erred by limiting an “entire oscillator” to one “that does not require a control signal.” We hold that the term is properly construed as one “that does not require a command input to change the clock frequency.”

The district court erred by holding that the patentee disclaimed any use of a command signal by the entire oscillator. Instead, the patentee disclaimed *a particular use* of a command signal—using a command signal to change the clock frequency. The patentee argued during prosecution that Sheets was distinguishable from the '336 patent claims because Sheets requires “a command input . . . to change the clock speed.” J.A. 2127. It de-

scribed Sheets' system "for providing clock control signals to an external clock" as "unrelated" to the claimed invention. J.A. 2117. Conversely, it stated that in the '336 patent, "[n]o command input is necessary to change the clock frequency." J.A. 2127. It argued its claims did not "rely upon [the] provision of frequency control information to an external clock" taught in Sheets because all claimed components were located on the same substrate. J.A. 2117. By placing all components on the same substrate, it "obviate[d]" the need for "the type of frequency control information described by Sheets." *Id.*

None of these statements disclaim an entire oscillator receiving a command input for any purpose. Every time the patentee mentioned a "control signal" or "command input," it did so only in the context of using a command input to modify the frequency of the CPU clock. This understanding is consistent with the patentee's characterization of the benefits of its invention. It argued that by placing the CPU and CPU clock on the same silicon substrate, the frequencies of both "automatically vary together." J.A. 2094. This eliminates the need for a command input to change clock frequency. As the patentee explained, "the oscillator or variable speed clock varies in frequency but does not require manual or programmed inputs or external or extra components to do so." *Id.*

We hold that an "entire oscillator" is one "that does not require a command input to change the clock frequency."

III. CONCLUSION

We hold that "an entire oscillator disposed upon said integrated circuit substrate" is "an oscillator located entirely on the same semiconductor substrate as the central processing unit that does not require a command input to change the clock frequency and whose frequency is not fixed by any external crystal." Although this minor modification to the district court's construction likely does

not affect the outcome in this case, because the parties stipulated to non-infringement under the district court's construction, the proper course of action is for us to vacate and remand. We vacate the district court's construction and remand for further proceedings.

VACATED AND REMANDED

COSTS

No costs on this appeal.