

United States Court of Appeals for the Federal Circuit

ULTIMATEPOINTER, L.L.C.,
Plaintiff-Appellant

v.

**NINTENDO CO., LTD.,
NINTENDO OF AMERICA INC.,**
Defendants-Appellees

2015-1297

Appeal from the United States District Court for the
Western District of Washington in No. 2:14-cv-00865-
RSL, Judge Robert S. Lasnik.

Decided: March 1, 2016

CHARLES JOHN ROGERS, Conley Rose, P.C., Houston,
TX, argued for plaintiff-appellant. Also represented by
GREGORY LOREN MAAG, THOMAS WARDEN, MICHAEL JAMES
GUTHRIE.

JERRY A. RIEDINGER, Perkins Coie, LLP, Seattle, WA,
argued for defendants-appellees. Also represented by
TYLER C. PETERSON; MARK CHRISTOPHER NELSON, STEVEN
M. GEISZLER, RICHARD SALGADO, Dentons US LLP, Dallas,
TX.

Before LOURIE, DYK, and WALLACH, *Circuit Judges*.

LOURIE, *Circuit Judge*.

UltimatePointer, LLC (“UltimatePointer”) appeals from a final judgment in favor of Nintendo Co., Ltd. and Nintendo of America, Inc. (collectively, “Nintendo”) after the district court granted summary judgment (1) that Nintendo did not infringe claims 1, 3, 5, 6, and 12 of UltimatePointer’s U.S. Patent 8,049,729 (the “’729 patent”), *UltimatePointer, LLC v. Nintendo Co*, No. 2:14-cv-00865-RSL, 2014 WL 7340604, at *1–2 (W.D. Wash. Dec. 22, 2014) (“*Infringement Opinion*”); and (2) that claims 1, 3, 5, and 6 of the ’729 patent are invalid as indefinite, *UltimatePointer, LLC v. Nintendo Co.*, 73 F. Supp. 3d 1305, 1308–09 (W.D. Wash. 2014) (“*Indefiniteness Opinion*”). For the reasons that follow, we *affirm* the judgment of noninfringement and *reverse* the determination of indefiniteness.

BACKGROUND

UltimatePointer is the owner of the ’729 patent, entitled “Easily Deployable Interactive Direct-Pointing System and Presentation Control System and Calibration Method Therefor.” The ’729 patent describes a handheld pointing device that can be used to control the cursor on a projected computer screen, thereby improving a presenter’s ability to control the cursor while making a presentation to an audience. *See* ’729 patent, col. 1 ll. 24–42. Figure 2 illustrates one configuration of the invention:

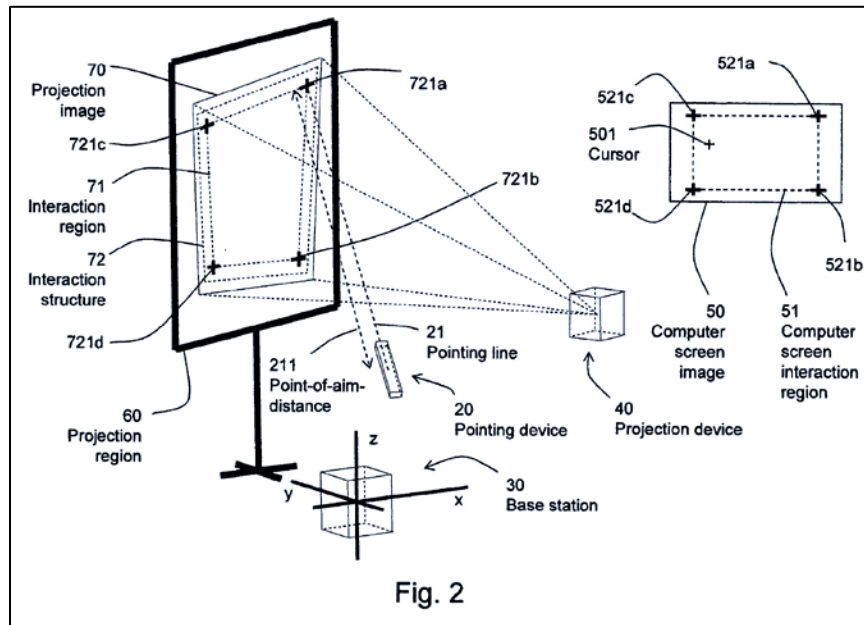

Id. fig. 2. The pointing device (20) can measure its location and orientation relative to the projected image (70), and use that measurement to determine where on the image to display the cursor. *Id.* col. 7 ll. 11–17. Claim 1 is exemplary and reads as follows:

1. An apparatus for controlling a feature on a computer generated image, the apparatus comprising:
 - a handheld device including:
 - an image sensor, said image sensor generating data related to the distance between a first point and a second point, the first point having a predetermined relation to the computer generated image and the second point having a predetermined relation to a handheld enclosure; and
 - a processor coupled to said handheld device to receive said generated data

related to the distance between a first point and a second point and programmed to use the distance between the first point and the second point to control the feature on the image.

Id. col. 33 l. 62–col 34 l. 8.

The specification describes two types of pointing devices: direct-pointing devices and indirect-pointing devices. *Id.* col. 1 l. 58–col. 2 l. 3. Indirect-pointing devices, for example, computer mice, are those “where the object of pointing (e.g., a cursor) bears an indirect relationship to the physical point-of-aim of the pointing device.” *Id.* col. 1 ll. 64–67. Direct-pointing devices, in contrast, are devices “for which the physical point-of-aim coincides with the item being pointed at, i.e., it lies on the line-of-sight.” *Id.* col. 1 ll. 61–63. Examples of direct-pointing devices “include the so-called ‘laser pointer’ and the human pointing finger.” *Id.* col. 1 ll. 63–64. According to the patentee, direct-pointing systems are “more natural to humans, allowing faster and more accurate pointing actions.” *Id.* col. 2 ll. 2–3. “[I]ndirect-pointing methods . . . do not provide the speed and intuitiveness afforded by direct-pointing systems.” *Id.* col. 2 ll. 42–43. In previous presentation systems, the cursor was often controlled by a computer mouse; that is, an indirect-pointing device. *See id.* col. 1 ll. 50–57.

Nintendo manufactures and sells the Wii video game system. The Wii system includes, among other things, a handheld Wii remote, a Wii console, and a sensor bar, as shown below:



Joint App. (“J.A.”) 14970.

The Wii console is a special-purpose computer that runs games and various other applications; it also provides audio and video output to a connected television. Appellees’ Br. 14. The sensor bar sits above or below the television and, contrary to its name, simply emits infrared light. J.A. 13667 ¶ 25. The Wii remote is the primary controller for the Wii system, and allows a user to interact with and play Wii games. J.A. 13667 ¶ 25.

The Wii remote can be used to control an on-screen cursor through the interaction of the remote and the sensor bar. J.A. 6272 ¶¶ 5, 7, 8. The front of the Wii remote detects the infrared light emitted by the sensor bar, and transmits information regarding that light to the Wii console. J.A. 6271 ¶¶ 5, 8. Based on the received information, the console displays the cursor on the television screen. J.A. 6271 ¶¶ 5, 8.

In 2011, UltimatePointer sued Nintendo and retailers of the Wii system in the United States District Court for the Eastern District of Texas (the “Texas district court”), alleging that the Wii system infringed several claims of the ’729 patent. UltimatePointer originally alleged that the Wii system infringed another patent as well, but has since withdrawn those allegations and, accordingly, that patent is no longer at issue. Because Nintendo Co. is a Japanese corporation with its headquarters in Kyoto, Japan, Nintendo of America is a Washington corporation

with its headquarters in Redmond, Washington, and UltimatePointer is a Delaware corporation, Nintendo moved to sever and stay the claims against the retailers and to transfer the case against Nintendo to the United States District Court for the Western District of Washington (the “Washington district court”). In response, UltimatePointer accused new products, sold by the retailers but not manufactured by Nintendo, of infringement; accordingly, the motions to sever and transfer were denied. Nintendo then petitioned this court for a writ of mandamus.

While the petition for mandamus was pending, proceedings continued in the Texas district court. On May 28, 2013, the district court issued an opinion construing numerous claim terms, many of which UltimatePointer contests on appeal. As will be explained *infra*, review of only one of those constructions is necessary to resolve this appeal: “handheld device” in claims 1, 3, 5, 6, and 12.

The parties disputed whether “handheld device” should be limited to a direct-pointing device, or whether the term also included indirect-pointing devices. The district court adopted Nintendo’s proposed construction, construing the term to mean “handheld direct pointing device.” *UltimatePointer, LLC v. Nintendo Co.*, No. 6:11-cv-00496-LED, 2013 WL 2325118, at *2–4 (E.D. Tex. May 28, 2013) (“*Claim Construction Opinion*”). The court reasoned that “[t]he specification characterizes the invention as a whole as a direct-pointing system that improves upon both indirect-pointing devices and prior direct-pointing devices,” and that indirect pointing is used only when direct pointing is impossible or undesirable. *Id.* at *3.¹ Even in those situations, the district court noted, the

¹ Although the district court explained its reasoning by referencing the written description of the other asserted patent, the specification of the referenced patent is

patent indicates that indirect pointing may be used “as described in the cited prior art.” *Id.* Thus, the district court concluded that “although the specification mentions indirect pointing, it is clear that the invention is aimed at direct pointing.” *Id.*

After claim construction, the petition for a writ of mandamus was granted, *In re Nintendo Co.*, 544 F. App’x 934 (Fed. Cir. 2013), and the action was transferred to the Washington district court. On December 22, 2014, the Washington district court then granted summary judgment that Nintendo did not infringe claims 1, 3, 5, 6, and 12 of the ’729 patent. *Infringement Opinion*, 2014 WL 7340604, at *1.

Although there were several bases for the district court’s decision, the primary basis was that the Wii remote was not a “handheld device,” as the term had been construed by the Texas court. The Washington court began by noting that, under the Texas court’s construction, the claims required a “‘direct,’ as opposed to an ‘indirect,’ pointing device,” *id.*, which the court characterized as “a product that places the cursor on the screen at the physical point of aim,” *id.* at *2. The Washington court concluded that UltimatePointer had not put forth sufficient evidence to survive summary judgment because the Wii remote was an indirect pointing device, not a direct one. *Id.* at *1–2. Specifically, the Washington court determined that although the Wii system can give the impression that the cursor is placed as a result of the user’s aim, “in reality it is the remote’s interaction with the Wii sensor bar, not the screen, that is relevant to the placement of the cursor.” *Id.* at *2. Accordingly, “[i]f the sensor bar is placed elsewhere, such as perpendicular to

identical to the specification of the ’729 patent, in relevant part, so the court’s reasoning applies with equal force to the ’729 patent.

the screen or behind the user, the user must aim the remote towards the sensor bar . . . in order to have the cursor appear on the screen.” *Id.*

In a separate opinion issued on the same day, the Washington district court concluded that the claim limitation “a handheld device including: an image sensor, said image sensor generating data . . .” in claims 1, 3, 5, and 6 of the ’729 patent rendered those claims invalid as indefinite. *Indefiniteness Opinion*, 73 F. Supp. 3d at 1308 (quoting ’729 patent, col. 33 ll. 64–65). The court reasoned that although the claims were directed to an apparatus (the handheld device including an image sensor), the claims also contained a method step (that the image sensor generates data). The court therefore determined that it was unclear whether the system claims were infringed when the apparatus was created, or when the apparatus was put to the specified use. *Id.* (citing *Rembrandt Data Techs., LP v. AOL, LLC*, 641 F.3d 1331, 1339–40 (Fed. Cir. 2011)).

The district court entered judgment against UltimatePointer and for Nintendo on December 24, 2014. J.A. 34. UltimatePointer timely appealed. We have jurisdiction pursuant to 28 U.S.C. § 1295(a)(1).

DISCUSSION

I. CLAIM CONSTRUCTION

We first address UltimatePointer’s argument that the Texas district court erred in its construction of the term “handheld device.”

The ultimate construction of a claim term is a legal conclusion that is reviewed *de novo*; similarly, interpretations of “evidence intrinsic to the patent (the patent claims and specifications, along with the patent’s prosecution history),” are legal conclusions, which are also reviewed *de novo*. *Teva Pharm. USA, Inc. v. Sandoz, Inc.*, 135 S. Ct. 831, 841 (2015). Any “subsidiary factfinding”

made by the district court based on extrinsic evidence is reviewed for clear error. *Id.*

Words in a claim “are generally given their ordinary and customary meaning”; that is, “the meaning that the term would have to a person of ordinary skill in the art in question at the time of the invention.” *Phillips v. AWH Corp.*, 415 F.3d 1303, 1313 (Fed. Cir. 2005) (en banc). “Importantly, the person of ordinary skill in the art is deemed to read the claim term not only in the context of the particular claim in which the disputed term appears, but in the context of the entire patent, including the specification.” *Id.* “[T]he specification ‘is always highly relevant to the claim construction analysis. Usually, it is dispositive; it is the single best guide to the meaning of a disputed term.’” *Id.* at 1315 (quoting *Vitronics Corp. v. Conceptronic, Inc.*, 90 F.3d 1576, 1582 (Fed. Cir. 1996)). See also *Trustees of Columbia Univ. v. Symantec Corp.*, ___ F.3d ___, No. 15-1146, 2016 WL 386068, at *2–3 (Fed. Cir. Feb. 2, 2016).

We have cautioned against importing limitations from the specification into the claims when performing claim construction, *Innogenetics, N.V. v. Abbott Labs.*, 512 F.3d 1363, 1370 (Fed. Cir. 2008); however, we have also recognized that “repeated derogatory statements” can indicate that the criticized technologies were not intended to be within the scope of the claims, *Chicago Bd. Options Exch. v. Int’l Sec. Exch.*, 677 F.3d 1361, 1372 (Fed. Cir. 2012).

UltimatePointer argues that the Texas district court imported the “direct pointing” limitation from the specification into claims 1, 3, 5, 6, and 12. Although UltimatePointer recognizes that “specific embodiments [in the ’729 patent] may be ‘aimed’ at direct pointing,” it argues that those embodiments do not restrict the broad claim language. Appellant’s Br. 26. The correct analysis, UltimatePointer argues, requires determining whether the patentee explicitly defined the relevant claim term or

disclaimed claim scope. Because the patentee did not provide an explicit definition or disclaim subject matter, UltimatePointer continues, reading “direct pointing” into the claims was incorrect and the Texas district court’s construction should be reversed in favor of “a piece of equipment or system component intended to be held in the user’s hand.” *Id.* at 24.

UltimatePointer also argues that, even if the Washington district court was correct in construing the “handheld device” to be a direct-pointing device, the court incorrectly further limited the claim construction in resolving summary judgment by requiring that the Wii remote “place[] the cursor on the screen at the physical point of aim.” *Id.* at 28–31.

Nintendo responds that direct pointing “is intertwined with every facet of the ’729 patent.” Appellees’ Br. 33. At every turn, Nintendo argues, the specification of the ’729 patent extolls direct pointing and disparages indirect pointing. Because the inventor described his invention as encompassing direct pointing and repeatedly criticized indirect pointing, Nintendo continues, UltimatePointer may not now claim that indirect pointing is within the claim scope.

We agree with Nintendo that the district court did not err in construing “handheld device” as “handheld direct pointing device.” The specification repeatedly emphasizes that the invention is directed to a direct-pointing system. The title of the invention explicitly states that the invention is an “Easily-Deployable Interactive *Direct Pointing* System . . .” (emphasis added). See *Exxon Chem. Patents, Inc. v. Lubrizol Corp.*, 64 F.3d 1553, 1557 (Fed. Cir. 1995) (using patent title to inform claim construction). The specification also repeatedly emphasizes that the system is for interacting with a presentation in a “direct-pointing” manner, ’729 patent, col. 14 ll. 25–28, 33–36, 46–49; col. 15 ll. 3–6; col. 20 ll. 32–35, and even describes

the handheld device as a “direct-pointing device,” *id.* col. 24 ll. 45–46, 51–53; col. 31 ll. 21–24.

The written description also emphasizes how direct pointing is superior to indirect pointing. In the “Background of the Invention,” the patentee notes that “pointing devices may be classified” as either direct or indirect-pointing devices, *id.* col. 1 ll. 58–60, and that “[i]t needs no argument that direct-pointing systems are more natural to humans, allowing faster and more accurate pointing actions,” *id.* col 2 ll. 1–3.

The written description further disparages indirect pointing. For example, indirect pointing is criticized as “less natural” than direct pointing, *id.* col. 2 ll. 35–36, and as not providing “the speed and intuitiveness afforded by direct-pointing systems,” *id.* col. 2 ll. 41–43. Even a prior art hybrid system, using both direct and indirect pointing, is criticized as not “afford[ing] the fast and more accurate interactive pointing actions provided by some other direct-pointing systems,” *id.* col. 4 ll. 52–54, and another hybrid system is criticized for not providing “the desired flexibility afforded by truly direct-pointing methods,” *id.* col. 5 ll. 1–3. Although the ’729 patent does include one embodiment where the handheld device “may include a conventional, indirect pointing device,” indirect pointing is only used “where direct pointing is not possible or not desired,” *id.* col. 30 ll. 23–26, thus even further disparaging indirect pointing.

Taken together, the repeated description of the invention as a direct-pointing system, the repeated extolling of the virtues of direct pointing, and the repeated criticism of indirect pointing clearly point to the conclusion that the “handheld device” in claims 1, 3, 5, 6, and 12 is limited to a direct-pointing device.

UltimatePointer’s arguments do not require a different result. UltimatePointer argues that the term “handheld device” has an ordinary meaning not limited to

direct pointing and, absent a clear definition or clear disclaimer from the patentee, that plain meaning should control. Appellant’s Br. 25. Adopting UltimatePointer’s “ordinary meaning,” however, would incorrectly require us to divorce the claim language from the repeated direct-pointing description and indirect-pointing criticism in the specification. In *Decisioning.com, Inc. v. Federated Department Stores, Inc.*, we rejected a proposed broad claim construction that was not supported by the specification, although we recognized that the construction was plausible if “[d]ivorced from the specification.” 527 F.3d 1300, 1308 (Fed. Cir. 2008) (per curiam). Even in *Pacing Technologies, LLC v. Garmin International, Inc.*, the main case that UltimatePointer relies on to support its argument, we stated that “claim terms are construed in light of the specification and prosecution history, not in isolation.” 778 F.3d 1021, 1024 (Fed. Cir. 2015). In other words, UltimatePointer’s argument that a court may only deviate from the ordinary meaning when there is an explicit definition or disclaimer does not apply because the ordinary meaning of “handheld device,” when read in the specific context of the specification of the ’729 patent, is limited to a direct-pointing device. See *Trustees of Columbia Univ.*, 2016 WL 386068, at *3 (“The only meaning that matters in claim construction is the meaning in the context of the patent.”).

UltimatePointer’s argument that the Washington district court impermissibly narrowed the Texas district court’s claim construction is similarly unpersuasive. The language used by the Washington court—“a product that places the cursor on the screen at the physical point of aim”—is taken directly from the patent, where the patentee defined “direct-pointing devices” as “devices for which the physical point-of-aim coincides with the item being pointed at.” ’729 patent, col. 1 ll. 60–62. Accordingly, the Washington district court did not err in its construction of “handheld device.”

II. NONINFRINGEMENT

UltimatePointer next argues that even if the Texas district court's construction of "handheld device" was correct, the Washington district court nonetheless erred in granting summary judgment of noninfringement.

We review a district court's decision to grant summary judgment under the law of the regional circuit in which the district court sits, here, the Ninth Circuit. *Classen Immunotherapies, Inc. v. Elan Pharm., Inc.*, 786 F.3d 892, 896 (Fed. Cir. 2015). In the Ninth Circuit, summary judgment is reviewed *de novo*. *Burke v. Cty. of Alameda*, 586 F.3d 725, 730 (9th Cir. 2009). Summary judgment is appropriate when, drawing all reasonable inferences in favor of the nonmovant, there is "no genuine dispute as to any material fact and the movant is entitled to judgment as a matter of law." Fed. R. Civ. P. 56(a); *see Anderson v. Liberty Lobby, Inc.*, 477 U.S. 242, 255 (1986).

UltimatePointer argues that it introduced evidence sufficient to generate a genuine dispute of material fact that the Wii remote is a "handheld direct pointing device," as required by the claims, because it presented evidence in the form of Nintendo's manuals for the Wii system, Nintendo's technical documents, analyses by experts, and a verified video exhibit of the Wii remote in operation. Specifically, UltimatePointer argues that when the Wii system is arranged and used as Nintendo instructs the user to arrange and use the system, the system causes the cursor to be displayed at the point-of-aim of the Wii remote.

Nintendo responds that the Wii remote does not perform direct pointing because it is the remote's interaction with the sensor bar, not the screen, that controls the placement of the cursor; for example, if the sensor bar is placed elsewhere, any approximation of direct pointing disappears. As a result, according to Nintendo, the Wii remote is an indirect, not a direct, pointing device. To be

a direct pointing device, Nintendo argues, the Wii remote would need to perform various calculations to account for distance, the size of the television screen, and the position of the Wii remote in space.

We agree with the district court and Nintendo that the Wii remote is an indirect, not a direct, pointing device, and that there is no genuine dispute of material fact on that point. All of the evidence establishes that it is the relationship between the Wii remote and the sensor bar, not the Wii remote and the television screen, that allows the Wii system to function. The object of pointing, *viz.*, the cursor, is displayed, not based on the relationship between the Wii remote and where the Wii remote is pointing on the television screen, but instead based on the relationship between the Wii remote and the sensor bar. Although the Wii system may create the illusion of direct pointing, in fact, the cursor is displayed based on an indirect, not a direct, relationship.

UltimatePointer's proffered evidence does not otherwise generate a genuine dispute of material fact. Nintendo's manuals instruct users how to operate the Wii system, and do not describe the interaction between the Wii remote and the sensor bar; similarly, the video of the Wii's operation simply illustrates how the Wii remote is used, not how it works. Moreover, the manner in which Nintendo referred to the Wii remote in its technical documents does not mean that the Wii remote performs direct pointing as that term is defined within the '729 patent. Finally, although UltimatePointer's technical experts opined that the Wii remote performed direct pointing, they did not contest the manner in which the Wii system functions. As it is that functionality—the interaction between the Wii remote and sensor bar—on which we rest our holding, those expert opinions cannot give rise to a genuine dispute of material fact.

To counter Nintendo's statement that moving the sensor bar removes any approximation of direct pointing, UltimatePointer responds that the fact that a system can be arranged in a noninfringing manner does not avoid infringement; *i.e.*, that "imperfect practice of an invention does not avoid infringement," Appellant's Br. 52–53 (quoting *Paper Converting Mach. Co. v. Magna-Graphics Corp.*, 745 F.2d 11, 20 (Fed. Cir. 1984)), and that "an accused device that 'sometimes, but not always, embodies a claim[] nonetheless infringes,'" *id.* at 53 (quoting *Broadcom Corp. v. Emulex Corp.*, 732 F.3d 1325, 1333 (Fed. Cir. 2013)). Although UltimatePointer is correct in principle, that principle does not apply to the facts here. *Paper Converting*, *Broadcom*, and similar cases apply when an accused system infringes in one manner of operation, but does not infringe in another manner. *See, e.g., Bell Commc'ns Research, Inc. v. Vitalink Commc'ns Corp.*, 55 F.3d 615, 622–23 (Fed. Cir. 1995). In the present case, the Washington district court found, and we agree, that the Wii system does not infringe in *any* arrangement. *Infringement Opinion*, 2014 WL 7340604, at *2. That the Wii system does not approximate direct pointing when the sensor bar is moved simply shows that the Wii remote performs indirect, not direct, pointing. Accordingly, the district court did not err in granting summary judgment of noninfringement.

For the reasons explained previously, the Texas district court did not err in construing the term "handheld device," and the Washington district court did not err in granting summary judgment of noninfringement based on that construction. Because those determinations entirely resolve UltimatePointer's infringement appeal, we need not, and do not, address UltimatePointer's challenges to other claim constructions and the associated infringement arguments.

III. INDEFINITENESS

UltimatePointer also challenges the Washington district court’s determination that claims 1, 3, 5, and 6 of the ’729 patent are invalid as indefinite.

We review a district court’s ultimate determination that a claim is invalid as indefinite under 35 U.S.C. § 112 ¶ 2 *de novo*,² although, as with claim construction, any factual findings by the district court based on extrinsic evidence are reviewed for clear error. *Eidos Display, LLC v. AU Optronics Corp.*, 779 F.3d 1360, 1364–65 (Fed. Cir. 2015). Neither party alleges that the district court relied on extrinsic evidence in reaching its conclusion that the claims are invalid as indefinite, and so our review is *de novo*.

Section 112 requires that a patent specification “conclude with one or more claims particularly pointing out and distinctly claiming the subject matter which the applicant regards as his invention.” The Supreme Court has read this provision to require that “a patent’s claims, viewed in light of the specification and prosecution history, inform those skilled in the art about the scope of the invention with reasonable certainty.” *Nautilus v. Biosig Instruments, Inc.*, 134 S. Ct. 2120, 2129 (2014). We have held that “a single claim covering both an apparatus and a method of use of that apparatus” fails to meet the requirements of § 112 because “it is unclear whether infringement . . . occurs when one creates a[n infringing] system, or whether infringement occurs when the user actually uses [the system in an infringing manner].”

² Because the ’729 patent was filed before the adoption of the Leahy-Smith America Invents Act, Pub. L. No. 112-29, § 3, 125 Stat. 284, 285–93 (2011), the prior version of § 112 governs. See *Fleming v. Escort, Inc.*, 774 F.3d 1371, 1374 n.1 (Fed. Cir. 2014).

IPXL Holdings, LLC v. Amazon.com, Inc., 430 F.3d 1377, 1384 (Fed. Cir. 2005). Nonetheless, “apparatus claims are not necessarily indefinite for using functional language.” *Microprocessor Enhancement Corp. v. Texas Instruments Inc.*, 520 F.3d 1367, 1375 (Fed. Cir. 2008) (“*MEC*”). If an apparatus claim “is clearly limited to a[n apparatus] possessing the recited structure and *capable* of performing the recited functions,” then the claim is not invalid as indefinite. *Id.* (emphasis in original).

The district court concluded that claims 1, 3, 5, and 6 of the ’729 patent are directed to both an apparatus and a method for using that apparatus because they claim “a handheld device including: an image sensor, said image sensor generating data” and other similar “generating data” limitations. *Indefiniteness Opinion*, 73 F. Supp. 3d at 1308 (quoting ’729 patent, col. 33 ll. 64–65). The court concluded that the inclusion of the “image sensor generating data” limitation made it unclear whether infringement occurred when an infringing system is assembled, or when “the apparatus is used to perform the specified function.” *Id.* Accordingly, the court concluded that the claims were invalid as indefinite.

UltimatePointer argues that the claims are not invalid as indefinite because they simply claim a handheld device with an image sensor capable of generating data, and recite sufficient structure for that capability. UltimatePointer contends that because claims 1, 3, 5, and 6 of the ’729 patent claim a structure in connection with the claimed functionality, the claims are more similar to those in *MEC*. *Id.* 60–62.

Nintendo responds that the claims do not clearly tie the functional language to the device’s capability. Nintendo argues that the district court’s decision is consistent with this court’s precedent, and that the United States Patent and Trademark Office (“USPTO”) routinely rejects

claims similar to those appearing in the '729 patent on *IPXL* grounds.

We agree with UltimatePointer that claims 1, 3, 5, and 6 of the '729 patent are not invalid as indefinite, as the claims do reflect the capability of the claimed apparatus. Unlike *IPXL* and similar cases, the claims at issue here make clear that the “generating data” limitation reflects the capability of that structure rather than the activities of the user.

In reaching this conclusion, review of our precedent is instructive. In *IPXL*, our first case to address the claiming of two statutory classes, the claim at issue recited a system including input means, wherein “the user uses the input means” *IPXL*, 430 F.3d at 1384. The claims were unclear whether infringement occurred when the system was created, or when the user used the system. *See id.*

We also affirmed a district court’s conclusion finding a claim invalid as indefinite for being directed to two statutory classes in *In re Katz Interactive Call Processing Patent Litigation*, 639 F.3d 1303, 1318 (Fed. Cir. 2011). In that case, the claims were directed to a system with an interface for providing automated voice messages to certain callers, “wherein said certain of said individual callers digitally enter data.” *Id.* Although the patentee argued that this clause indicated functional capability, we held that the clause was “directed to user actions, not system capabilities.” *Id.*

In *MEC*, however, we reversed a district court’s determination that a claim directed to a computer processor with different stages, including “performing a boolean algebraic evaluation,” “producing an enable-write,” later “enabling” or “disabling,” and, at a different stage, “determining,” was directed to two different statutory classes. *MEC*, 520 F.3d at 1371–72. Instead, we found that the claim was “clearly limited to a . . . processor possessing the recited structure and *capable* of performing

the recited functions.” *Id.* at 1375 (emphasis in original). Because the limitation only indicated a capability of the structure rather than actual use, the claim was not indefinite. *See id.*

In *HTC Corp. v. IPCom GmbH & Co., KG*, we also reversed summary judgment of indefiniteness when the claim was drawn to a mobile station for use with a network. 667 F.3d 1270, 1277 (Fed. Cir. 2012). The claim at issue included “storing,” “holding,” and other functional limitations, *id.* at 1274, but we concluded that those limitations “merely establish those functions as the underlying network environment in which the mobile station operates.” *Id.* at 1277. As the limitations only described the environment in which the network operated rather than indicating a method of use, however, the claim was not indefinite.

The claims here are most similar to those at issue in *MEC* and *HTC Corp.* Like those claims, the “data generating” limitations only indicate that the associated structures have this capability (for example, the image sensor and processor in claim 1) and do not require that any data be actually generated by the user. *See* ’729 patent, col. 33 l. 65–col. 34 l. 8. Unlike the claims in *IPXL* and *Katz*, the claims do not recite functionality divorced from the cited structure. Therefore, the claims do not reflect an attempt to claim both an apparatus and a method, but instead claim an apparatus with particular capabilities. Accordingly, we reverse the district court’s determination that claims 1, 3, 5, and 6 of the ’729 patent are invalid as indefinite.

CONCLUSION

We have considered the remaining arguments, but find them unpersuasive. For the foregoing reasons, the decision of the district court is affirmed in part and reversed in part.

AFFIRMED IN PART, REVERSED IN PART

COSTS

No costs.